

# CATHODE-RAY OSCILLOSCOPE TYPE 513

## INSTRUCTION MANUAL



TEKTRONIX, INC.

MANUFACTURERS OF CATHODE-RAY AND VIDEO TEST INSTRUMENTS

---

Sunset Highway and Barnes Road • P. O. Box 831 • Portland 7, Oregon, U. S. A.

Phone: CYpress 2-2611 • Cables: Tektronix

## NOTE

This instruction manual has been prepared to cover TEKTRONIX Type 513 Oscilloscopes of all serial number ranges. Text, diagrams, and parts lists have been expanded to incorporate all circuit modifications adopted during the course of manufacture. The serial ranges of instruments to which various modifications were applied before shipping from the factory have been noted wherever necessary.

However, because many instruments have been modified in the field and out of serial sequence, component values and circuitry of a given instrument may differ considerably from those indicated in this manual for its serial number. The user is urged, therefore, to enter whatever changes may be necessary to bring this manual into agreement with the present circuitry of his oscilloscope.

When ordering parts, always include the following information:

1. Instrument Type (513).
2. Instrument Serial Number (as, SN 9999).
3. Part Circuit Number (as, R999).
4. Part Description (value, type, rating, tolerance, etc.).
5. The 6-digit TEKTRONIX part number (as, 999-999).

## SAFETY NOTICE

This oscilloscope employs dangerously high voltages. Since some maintenance must be performed with the case removed, great care should be taken. Use only insulated tools, stand on a dry floor and if possible keep one hand in your pocket. Care should also be used in making any connections to the deflection plates of the cathode-ray tube through the access panel. It is advised that the access panel never be removed until the power has first been turned off. The instrument should not be operated with this protective cover removed.

# CONTENTS

<b>DESCRIPTION</b>	<b>SECTION 1</b>
Characteristics. Functions of Controls and Connections.	
<b>OPERATING INSTRUCTIONS</b>	<b>SECTION 2</b>
First-Time Operation. CRT Adjustments. Horizontal-Deflection System. Sweep Stability. Trigger Selector. Trigger Amplitude. Trigger Rate Generator. Sweep Time. Recurrent Sweep. Single Sweep. Sweep Magnifier. Ext. Sweep Input. Delay Trigger and Gate Generator. Sweep Output. +Gate Output. Sweep Length Control. Vertical-Deflection System. Signal Input Connection. Vertical Amplifier. Deflection Sensitivity. Input Coupling. Signal Delay. Direct Connection to Deflection Plates.	
<b>CIRCUIT INFORMATION</b>	<b>SECTION 3</b>
Block Diagram. Horizontal-Deflection System. Vertical-Deflection System. Power Supplies and CRT.	
<b>MAINTENANCE</b>	<b>SECTION 4</b>
General Information. Power Supply. Sweep Circuits. Calibrator Circuit. Vertical Amplifier. Delay Trigger and Gate.	
<b>DIAGRAMS AND PARTS LIST</b>	<b>SECTION 5</b>
Block Diagram. Sweep Circuit. Delayed Gate and Trigger. Trigger Rate Generator. Vertical Amplifier Output Stage. Vertical Amplifier Circuits. Power Supply. High Voltage Oscillator.	

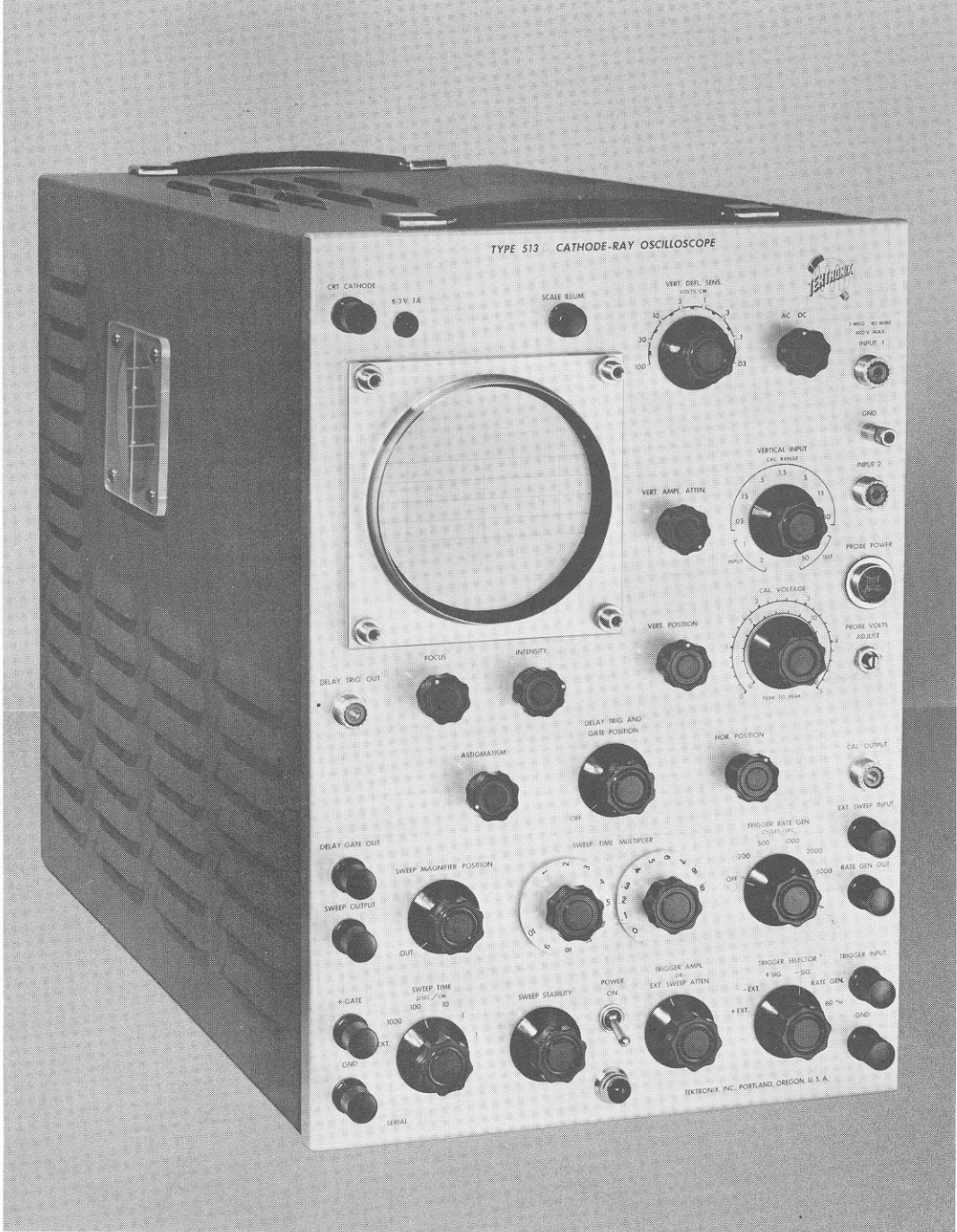

TYPE 513 CATHODE-RAY OSCILLOSCOPE

CRT CATHODE 6.3V 1A

SCALE KILIA

VERT DEF. SENS

AC DC



1 MEG. 40 MAMP. 600 V. MAX. INPUT 1

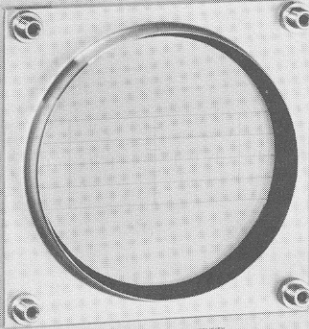

VERT AMPL. ATTN

VERTICAL INPUT CAL. RANGE

GND.

INPUT 2

PROBE POWER

CAL. VOLTAGE

PROBE VOLT. ADJUST

VERT. POSITION

YEAR TO PEAK

DELAY TRIG. OUT

FOCUS

INTENSITY

DELAY TRIG AND GATE POSITION

HOR. POSITION

CAL. OUTPUT

ASTIGMATISM

EXT. SWEEP INPUT

DELAY GATE OUT

SWEEP MAGNIFIER POSITION

SWEEP TIME MULTIPLER

TRIGGER RATE GEN

BATE GEN. SWIT

SWEEP OUTPUT

OUT

TRIGGER RATE GEN

TRIGGER RATE GEN

BATE GEN. SWIT

+GATE

EXT.

GND.

SERIAL

SWEEP TIME

SWEEP STABILITY

POWER ON

TRIGGER AMPL. OR EXT. SWEEP ATTN

TRIGGER SELECTOR

EXT. RATE GEN.

60 Hz

GND.

TEKTRONIX, INC. PORTLAND, OREGON, U.S.A.

# SECTION 1

## DESCRIPTION

The Tektronix Type 513D is a portable, self-contained, precision instrument specifically designed for displaying a plot of the variations with respect to time of a voltage pulse or wave, with self-contained means of measuring its duration and magnitude. It is primarily intended for study of short duration pulses.

It features a 5XP type cathode-ray tube with an accelerating voltage of 12KV, making it particularly useful where a high writing rate is required, or where it is desired to photograph single high speed sweeps. This handbook describes its characteristics, basic principles, operation and maintenance.

### CHARACTERISTICS

#### Dimensions

18 1/2" high, 12 1/2" wide, 21 1/2" deep (S/N 101-1019), 25 1/2" deep (S/N 1020 and up).

#### Weight

Approximately 75 lbs.

#### Power Requirements

105-125 or 210-250 volts, 50-60 cycle A.C.---580 watts maximum.

#### Sweep Circuit

Hard tube type, either triggered or recurrent as desired.

#### Sweep Time

Continuously variable, .01 sec. to .1 microsecond per centimeter of deflection. Calibration accuracy 5% or better.

#### Synchronizing Requirements

Internal--Leading or lagging edge of pulse or signal under observation producing .5 cm or more of deflection. 60-cycle power line frequency, or internal trigger rate generator.

External--0.15 to 50 volts (peak) square waves or sine waves (10 cps to 10 mc), or positive or negative pulses 0.15 to 15 V peak as short as 0.05 microsecond. External trigger input impedance, 1 megohm resistor paralleled by 25 mmfd. (An ext. attenuator should be used for triggers of over 50 volts peak.) A key connected between TRIGGER INPUT and GND. is suitable for triggering single sweeps. Sweep Lag---CRT is unblanked and sweep is operating in less than .1 microsecond after receipt of an infinitely short trigger pulse.

#### Sweep Magnification

Any portion of the sweep may be delayed and expanded approximately 5 times for detailed examination of the signal. (At the fastest sweeps the magnification is somewhat less.)

#### External Sweep Input

DC coupled via 100 K potentiometer and sweep amplifier. Maximum deflection sensitivity 1.5 V per cm. DC or peak-to-peak AC. Input impedance--100 K paralleled by 40 mmfd. (max. position). Maximum input voltage 400 volts D.C. or RMS A.C.

#### Vertical Amplifier

Four stages; third stage and output stage direct-coupled push pull; output stage twelve-section distributed.



### **A. C. Vertical Deflection Sensitivity**

Continuously variable from .03 volts/cm to 100 volts/cm., peak-to-peak (equivalent to approximately .01 volt/cm RMS).

### **D. C. Vertical Deflection Sensitivity**

Continuously variable from .03 volts/cm to 100 volts/cm, DC or peak-to-peak AC (equivalent to approx. .1 volt/cm RMS).

### **Probe**

R.C. frequency compensated. The sensitivity is reduced by a factor of 10 when the probe is used.

### **Input Impedance**

1 meg. shunted by 40 mmfd. (impedance is constant at all settings) 10 meg. shunted by 13 mmfd. with 10X probe.

### **Signal Input**

Two coaxial connectors. Either input may be selected by the VERTICAL INPUT switch. However, both signals cannot be displayed at the same time.

### **Maximum Input Signal**

600 volt peak.

### **Vertical Amplifier Transient Response**

Risetime (10-90%) .025 microsecond.

### **Vertical Amplifier Response**

D.C. to 18 mc. sensitivity of .3 volts/cm or lower. 2 cycles to 16 mc sensitivity .03 volts/cm or lower.

### **Signal Delay Network**

(513D only). Provides .25 microsecond signal delay. Permits observation of wavefront which triggers sweep.

### **Calibration Voltage**

Square wave at approximately 1 kc. Seven ranges, .05 volts to 50 volts full scale, continuously variable from zero. Accuracy within 2% of full scale.

### **Waveforms Available Externally**

6.3 volts 1 amp. max. at line frequency. Sweep sawtooth (pos. going) 15 volts peak amplitude.

### **Positive Gate**

40 volts peak from cathode-follower 10 K internal cathode resistor.

### **Delayed Gate**

Positive going, 30 volts peak from cathode follower. 10 K internal cathode resistor. The start of this delayed gate may be positioned at any point within approx. 1 1/2 cm. of the start of the sweep by the front panel control. Risetime approx. .75 microseconds.

### **Delayed Trigger**

Positive going trigger. The delayed trigger may be positioned at any point on the sweep up to approx. .3 microsecond of its start at fastest sweep speed. Output on coaxial connector from cathode follower, internal resistance 4.7K ohms. For shortest risetime it may be terminated in 100 ohms giving a 1/4 $\mu$ s pulse of 50 volts amplitude with a risetime of approximately 0.125 microseconds. Peak output voltage without external termination 100 volts.

### **Trigger Rate Generator**

Positive going trigger, output on coaxial connector from cathode-follower, internal resistance 4K ohms 60 volts amplitude. An external termination of 100 ohms may be used giving a peak output voltage of approx. 30 volts. P.P.S. 200 - 500 - 1000, 2500, 5000.

### **Cal Output**

Square wave calibrating voltage terminating in coaxial connector. Voltage 0 - 50 volts peak.

### **Cathode Ray Tube**

Type 5XP, 5 inch.  
Screen--P1, P2, P11 optional.

Accelerating Potential--12 KV total, regulated.

### **Connection to CRT Cathode**

Front panel binding post, or through access panel via .03 mfd. Capacitor RC = .003 sec.



Normally grounded at inside connector accessible through access panel.

### Access Panel

A removable access panel is located on the left side of the case. Short connections may be made directly to the deflection plates or to the cathode of the CRT. Cathode grounding strap is accessible here.

### Equipment Supplied

The equipment supplied with the Type 513D is listed below:

- Oscilloscope
- Probe 10X
- Binding post adapter
- Power cord
- Light filter
- Instruction manual

### Equipment Available But Not Supplied:

No equipment beyond that supplied is required for ordinary operation of the Type 513D oscilloscope. However, probes of other than 10X attenuation may be desirable for some applications. These will be supplied on special order.

Special attenuators may be needed in some cases to reduce the amplitude of the trigger to 50 volts peak or less. Normally, these may be constructed by the user of the Type 513D in the field. However, the factory will supply special attenuators on order.

The Tektronix Type 500 Scope-Mobile provides a sturdy, yet portable support for the Type 513D. With its large, rubber-tired wheels, it permits the oscilloscope to be moved with ease from one place to another.

## FUNCTIONS OF CONTROLS AND CONNECTIONS

A brief explanation of the function of each control and connection is given below. For a more detailed explanation, consult Section III, CIRCUIT DESCRIPTION.

### BACK OF CASE

**POWER INPUT** ---Receptacle in rear of case for cord. The Type 513D is normally supplied to operate from 105-125V AC 50-60 cycle. In case it is desired to use it on 210-250 V AC., refer to Section IV for wiring changes.

**FUSE** The fuse receptacle is located on rear of the instrument. A 6 amp. 250 volt "slo-blo" fuse is used if the Type 513D is wired for 105-125 V. A 3 amp. "slo-blo" fuse is used if wired for 215-250 V.

### FRONT PANEL

**POWER ON**--Switch on front panel controlling input power.

**INPUT 1**--Signal input to vertical amplifier. UHF coaxial connector permits use of Type A510 binding post adapter or Type P510A R. C. probe.

**INPUT 2** Alternate signal input to the vertical amplifier.

**VERTICAL INPUT** --Eleven-position switch for selection either INPUT 1 or INPUT 2, any one of seven square wave calibration ranges,

or either of two square-wave test ranges (through INPUT 1).

**VERT. DEFL.SENS.**--Combined 4 section R-C attenuator and amplifier stage selector, which in conjunction with the VERT. AMPL. ATTEN. provides continuously variable control of the vertical deflection sensitivity over the range of .03 volts to 100 volts peak-to-peak per centimeter.

**VERT. AMPL. ATTEN.** ---Potentiometer in cathode follower circuit to permit 3 to 1 variation in vertical amplifier gain.

**AC-DC**--Switch to provide optional direct or capacitive coupling of vertical amplifier. .1 mfd. input capacitor used in AC position (R-C .01 sec.).

**CAL. VOLTAGE** --Calibrated potentiometer used in conjunction with CAL. RANGE and TEST setting of the VERTICAL INPUT selector to provide continuously variable amplitude control of the square wave calibrator.

**CAL. OUTPUT--UHF** -----Connector to arm of CAL. VOLTAGE potentiometer. Useful as calibrated test signal.

**PROBE POWER** --Four-prong socket to provide plate and filament power for cathode-follower probe, or for auxiliary equipment. See operat-



ing instructions for limitations of use. Current from the 2225-volt terminal should not exceed 8 ma for continuous use or 15 ma for intermittent use.

**PROBE VOLTS ADJUST** - - - - - A potentiometer (screwdriver adj.) controlling the grid of the cathode follower which sets the voltage on the PROBE POWER socket (prong #3).

**VERT. POSITION** - - - Potentiometer controlling grid bias on one side of Vert. Amp. cathode-coupled push-pull 3rd stage. Resultant changes in the operating points of the 3rd stage are direct coupled to the output stage, thus shifting the image vertically.

**HORIZONTAL POSITION** - - - Potentiometer controlling grid bias of one side of horizontal amplifier cathode-coupled 1st stage. This change is direct coupled to output stage, thus shifting horizontal position of the trace.

**EXT. SWEEP INPUT** - - - Binding post connecting to sweep amplifier via EXT. SWEEP ATTEN. When SWEEP TIME switch is in EXT. position, (100 k input impedance).

**TRIGGER RATE GEN.** - - - 6 position switch selects any of 5 fixed frequencies to trigger the sweep or to trigger external equipment connected to binding post marked RATE GEN. OUT. Plate voltage is removed from the TRIGGER RATE GEN. (tubes V507 and V508) when the switch is in the OFF position. (When not in use should be in OFF position.)

**RATE GEN. OUT** - - - Binding post connecting to TRIGGER RATE GEN. via cathode follower V508. Furnishes a positive pulse of app. 60V peak to trigger external equipment at the same time it is triggering the sweep.

**TRIGGER SELECTOR** - - - Switch to select either internal triggers from the signal under observation, external triggers of either polarity via binding post marked TRIGGER INPUT, output to TRIGGER RATE GEN., or power line frequency.

**TRIGGER INPUT** - - - Connector to the +EXT. and -EXT. positions of TRIGGER SELECTOR switch.

**GND.** - Binding post connecting to the chassis.

## **TRIGGER AMP. OR EXT. SWEEP ATTEN.** - - - - -

Dual potentiometer. Front section controls bias applied to trigger amplifier tube (V103) and thereby determining the size of the trigger pulse required to start the multivibrator.

Back section controls the signal applied to the grid of the sweep amplifier when the SWEEP TIME switch is set in the EXT. position.

**SWEEP STABILITY** - - - Potentiometer controlling grid bias of multivibrator (V104). The setting determines whether the sweep will "free run" or must be triggered.

**SWEEP TIME** - - - Switch selecting appropriate capacitors for the multivibrator and sweep generator circuits. These timing capacitors, in conjunction with the SWEEP TIME MULTIPLIER, control the sweep time per cm. When set to EXT. position the sweep amplifier is connected to the EXT. SWEEP INPUT binding post, via the EXT. SWEEP ATTEN.

**+GATE** - - - Binding post giving a positive gate of approx. 40 volts peak, starting at the same time as the sweep and of the same duration.

**SWEEP OUTPUT** - - - Binding post connection to sweep generator via cathode follower (V118A). 15 volts peak amplitude.

**SWEEP MAGNIFIER POSITION** - - - Potentiometer controlling bias voltage applied to grid of sweep magnifier (V119) and thereby determining portion of sweep to be magnified. When turned to OUT, the sweep magnifier is disconnected from the circuit. (Should be in OUT position when not in use.)

**SWEEP TIME MULTIPLIER** - - - Variable timing resistors in the multivibrator and sweep generator circuits. Consist of a calibrated dual, ten range step switch, and a dual continuously-variable control which in conjunction with the SWEEP TIME switch, determines the sweep time per cm.

**DELAY TRIGGER AND GATE POSITION** - - - Potentiometer controlling the bias on V510 thereby determining the point along the sweep at which the delayed gate and trigger start. In the OFF position plate voltage is removed from all tubes in the Delayed Trigger and Gate Generator (V501 to V505). Control should be turned to OFF when not in use.





**DELAY GATE OUT** ---Binding post for connection to the Delayed Gate generator via cathode follower (V503B). Peak output 30 volts.

**DELAY TRIGGER OUT** ---U.H.F. coaxial fitting for connection to the Delayed Trigger generator via cathode follower (V505). Peak output 50 volts when terminated with 100 ohms external resistor.

**ASTIGMATISM** ---Potentiometer setting grid voltage of cathode follower (V114B), thereby adjusting potential on cathode-ray tube anode (A2) with respect to the deflection plates. Correct adjustment of this control makes possible a sharp focus of the image in both directions simultaneously.

**FOCUS** ---Potentiometer controlling the voltage applied to the focus anode (pin 5) of the CRT and thereby the sharpness of the image.

**INTENSITY** ---Potentiometer controlling the average grid of the CRT and thereby the brightness of the image.

**CRT CATHODE** ---Binding post permitting connections of external modulating signal to the cathode of the cathode-ray tube via a .03 mfd. capacitor. (This connection may also be reached through the side access panel.)

**6.3V 1A**--Connection to 6.3V line frequency heater supply to provide current for the TEKTRONIX Type 51 Camera Mount. May also be used for other low current applications.

**SCALE ILLUM.** ---Variable resistor controlling brightness of the lamps which illuminate the

plastic graticule over the face of the cathode-ray tube.

#### **SIDE OF CASE**

**ACCESS PANEL** ---A split, removable cover to permit direct connection to the deflection plates of the CRT.

**SWEEP LENGTH ADJ.** ---Potentiometer (screwdriver adjustment), to adjust bias on multivibrator (V117) thereby causing it to fire at a predetermined amplitude of the sweep waveform and in conjunction with V116 and V115 blanking the CRT when the sweep reaches this given amplitude.

**D-1 VOLTS** ---Potentiometer (screwdriver adjustment), to permit setting the average potential of deflection plate D-1 so that it is approximately equal to the voltage of the other plates in order to secure the best focus. (See Section IV for proper adjustment method.)

**D-2 VOLTS** ---Potentiometer (screwdriver adjustment), to permit setting the average potential of deflection plate D-2.

**C.F. ADJUST** ---Potentiometer (screwdriver adjustment), to set the potential of the cathode of V8 to equal that of cathode V7 so that there is no change in vertical position with a change in setting of the VERT. AMP. ATTEN.

**VERT. POS. ADJUST** ---Potentiometer (screwdriver adjustment), to set the range over which the front panel VERT. POSITION control will operate.



# SECTION 2

## OPERATING

### INSTRUCTIONS

The Type 513D may be operated in any normal indoor location, or in the open if protected from moisture. If the instrument has been exposed to dampness, it should be left in a warm room until thoroughly dry before being placed in operation.

To prevent excessive interior temperatures, it is important to allow adequate ventilation for the oscilloscope. Several inches clearance should be provided at the sides, back and top of the case.

If the Type 513D is used continuously for the same application, and only one setting of the controls is required, it is advisable to periodically check the instrument at all control settings to be sure it is in normal operating condition. For example, if only direct connection to the vertical deflection plates of the CRT is used, a defect in the vertical amplifier might not become evident. Operation of the controls also helps to prevent accumulation of dirt and tarnish on their contacts.

Although the components are well supported and the adjustments are very stable in setting to allow for portable operation, the Type 513D should not be subjected to excessive vibration or rough handling.

#### FIRST-TIME OPERATION

To place the Type 513D in operation for the first time, the following procedure is suggested:

1. Connect to a source of 50-60 cycle, 105-125V power (or 210-250V is transformer connections are changed as directed in Section IV).

2. Set controls as indicated below:

VERTICAL INPUT	50V CAL. RANGE
	Position
VERT. DEFL. SENS.	10-30 v/cm
VERT. AMPL. ATTEN.	Clockwise
AC-DC	AC
CAL. VOLTAGE	0
TRIGGER SELECTOR	+ SIG.
TRIGGER AMPL.	Counterclockwise
SWEEP STABILITY	Counterclockwise
SWEEP TIME	100 $\mu$ sec/cm
SWEEP TIME	5.0
MULTIPLIER	
ASTIGMATISM	2/3 counterclockwise
FOCUS	Center
INTENSITY	Counterclockwise

HOR. POSITION	2/3 clockwise
VERT. POSITION	Center
SWEEP MAGNIFIER	OUT
DELAY TRIGGER AND	OFF
GATE POSITION	
TRIGGER RATE GEN.	OFF

3. Turn POWER switch to ON and wait about 60 seconds.

4. Very carefully turn up INTENSITY control until a spot just appears on the CRT screen.

**CAUTION** --DO NOT ALLOW THIS SPOT TO BE EXCESSIVELY BRIGHT OR TO REMAIN LONG IN ONE POSITION. WITH 12KV on the C.R.T. THE SCREEN WILL BE DAMAGED IN ONLY A FEW SECONDS IF THE INTENSITY OF THE STATIONARY SPOT IS TURNED UP TOO HIGH.

5. Advance the SWEEP STABILITY control until a sweep appears.

6. Adjust the VERT. POSITION until the line is in the center of the screen.



7. Adjust the HOR. POSITION control until the sweep starts at the left hand edge of the screen.
8. Back off the SWEEP STABILITY control until the sweep just stops.
9. Set the CAL VOLTAGE control to 3(30 volts).
10. Advance the TRIGGER AMPL. control until a stable image of a square wave is displayed on the screen.
11. Readjust the FOCUS and ASTIGMATISM controls until the image is sharpest.

The oscilloscope is now displaying the square wave calibrating voltage. To observe other wave forms, connect them to either INPUT 1 or INPUT 2 and set the VERTICAL INPUT selector accordingly. Adjust the VERT. DEFL. SENS. and VERT. AMPL. ATTEN. for the desired vertical deflection, and select appropriate sweep time by means of the SWEEP TIME and SWEEP TIME MULTIPLIER controls.

## CRT ADJUSTMENTS

The Type 513D uses a Type 5XP cathode-ray tube. This tube has a five-inch screen and utilizes electrostatic focus and deflection. Short (P11), medium (P1), and long (P2) persistence screens are optional. Post-accelerating elec-

trodes (3 Bands) are used to provide increased brightness. The total accelerating potential of about 12,000 volts gives a sharp, bright image suitable for photographic recording, or visual observation of high speed waveforms at low repetition rates.

The edge lighted plastic graticule, scribed in centimeter graduations, is used in conjunction with the calibrated sweep and vertical deflection controls to obtain accurate measurements of time and amplitude. Intensity of the lines may be varied by means of the SCALE ILLUM. control to compensate for variations in trace intensity and ambient room light. A filter of proper color to provide maximum trace contrast is located under the graticule. If a CRT with a different type screen is installed, the corresponding filter may be obtained from the factory.

Two separate controls, FOCUS and ASTIGMATISM, permit good focus to be obtained on both horizontal and vertical lines simultaneously. These controls are interdependent in setting, and also vary slightly at different levels of intensity. In general, it is desirable to use the minimum INTENSITY setting required for adequate observation of the trace. This will vary with ambient light conditions, writing rate, repetition rate, etc.

## HORIZONTAL-DEFLECTION SYSTEM

The sweep circuit of the Type 513D is different from the gas tube type usually employed in portable oscilloscopes. It is much more flexible and capable of synchronizing with much higher frequencies than conventional sweep circuits. Fundamental frequencies as high as 10 mc can be easily observed. By one simple adjustment, the sweep can be made to run recurrently or triggered as desired.

In a recurrent or sawtooth sweep as generated by a gas tube or similar device, the synchronization takes place at the end of the sweep. The sync impulse causes the beam to return to the left side of the tube where it immediately starts another sweep. Thus the sweep time must be a multiple of the signal period, or expressed

another way, the sweep frequency an integral fraction of the signal frequency.

In a triggered sweep circuit, each sweep is started independently of the preceding sweep by a trigger or synchronizing impulse. When no trigger is being received, the beam remains at the left side of the trace. When the trigger arrives, the beam goes linearly to the right for a time, in this case determined by the multi-vibrator pulse length. At the end of its sweep, it returns to the left side again to await another trigger. It is this variable waiting period which makes the synchronization so easy since the sweep time is now independent of the signal period. The triggered sweep makes it possible to view pulses such as used in radar and



television where the length of the pulse is very short compared to the space between pulses. This requires a fast sweep with a long waiting period. Waiting periods of 5000 times the sweep length are frequently used.

### **SWEEP STABILITY**

The SWEEP STABILITY control varies the multivibrator bias and therefore determines whether the sweep will oscillate recurrently or wait for a trigger impulse. Correct functioning for triggered operation is therefore obtained when it is set just under the point where oscillation takes place. The procedure is to remove the trigger source, turn the TRIGGER AMPL. control counterclockwise, advance the SWEEP STABILITY knob until a sweep appears, and then decrease it until it just disappears.

**NOTE** --When using the internal (+SIG. or -SIG.) trigger impulses to view fundamental frequencies above about 2 mc, it will be necessary to progressively advance the SWEEP STABILITY control somewhat above the normal operating point to secure a stable pattern.

### **TRIGGER SELECTOR**

This control selects the trigger impulses to be used from four sources, the line frequency (60 cycle), the trigger rate generator (RATE GEN.), the vertical amplifier (+SIG and -SIG), or the TRIGGER INPUT connector (+EXT. and -EXT.). Two positions are available for both the SIG and EXT sources. When using those marked (+), the sweep starts on the rising portion of the trigger impulse. The (-) positions start the sweep on the falling portion. For satisfactory operation in the EXT positions, a square or sine wave of 0.15 to 50 V or a pulse of 0.15 to 15 V should be provided. Larger triggers should be reduced by an external attenuator. In the RATE GEN position the sweep is triggered at the rate determined by the setting of the TRIGGER RATE GEN switch.

In the 60 cycle position the sweep is triggered by the power line frequency.

### **TRIGGER AMPLITUDE**

The TRIGGER AMPL. control adjusts the bias in the trigger amplifier and therefore the amplitude of the impulse which reaches the multi-

vibrator. After the SWEEP STABILITY is set as described previously, and the TRIGGER SELECTOR switch set to the correct position, advance the TRIGGER AMPL. control until a stable image is obtained. When the trigger source is a slowly changing wave such as a sine wave or sawtooth, adjustment of the TRIGGER AMPL. setting will change the phase of the signal relative to the start of the sweep.

In general, it is desirable to use the minimum TRIGGER AMPL. setting required to insure a stable image.

If poor synchronizing is experienced when the Type 513D is used to observe repetitive signals containing erratic peak voltages, such as produced by vibrating contacts, it may be possible to form a stabilized trigger signal by the use of auxiliary limiting and differentiating circuits. The TRIGGER SELECTOR switch should then be set to the proper EXT. polarity, and connection made to the TRIGGER INPUT.

If an external trigger source delivers more voltage than necessary, the sweep may be shortened or behave erratically. In this case the TRIGGER AMPL. control setting should be reduced. If it is not possible to get proper operation at any setting, the incoming trigger should be reduced with an external attenuator.

When employing an external source of synchronizing voltage, it may be possible, with careful adjustment of the TRIGGER AMPL. setting to control the time between the start of the sweep and the signal image. Thus, a signal may be moved along the sweep by adjusting the TRIGGER AMPL. setting.

### **TRIGGER RATE GENERATOR**

The function of this circuit is to trigger the fast sweeps at a low repetition rate where it is desired to limit the duty cycle. To operate the TRIGGER RATE GEN., turn the TRIGGER SELECTOR switch to RATE GEN. and turn the TRIGGER RATE GEN. switch to the frequency desired. The TRIGGER AMPL. and SWEEP STABILITY control are operated as described above. The output waveform is available simultaneously on the binding post marked RATE GEN. OUT. This is a positive pulse of approximately 30 volts peak amplitude when terminated in an external 100 ohm load. This waveform may be used to trigger external equipment at the same



time that it is triggering the sweep.

The TRIGGER RATE GENERATOR is only intended as a trigger source and is not intended as a frequency standard; therefore the frequencies (p.p.s.) as marked on the panel are approximate and are only held to a tolerance of +or-15%.

When not in use the TRIGGER RATE GENERATOR should be turned to the OFF position, as under some conditions there may be coupling through to the trigger amplifier which would cause unstable operation.

### **SWEEP TIME**

The combination of SWEEP TIME and SWEEP TIME MULTIPLIER controls allows the operator to vary the sweep time so that the total marked portion of the graticule (10 cm) is covered in any time from .1 sec. to 1 microsecond. The approximate number of microseconds for a horizontal deflection of 1 cm can be determined easily by multiplying the SWEEP TIME setting by the sum of the SWEEP TIME MULTIPLIER dial readings. Multiply this figure by ten to determine the time required to sweep the total portion of the graticule which is calibrated in cm.

**NOTE** -- For the most accurate reading of the sweep time the signal under observation should be confined to the center 8 cm of the screen.

The SWEEP TIME MULTIPLIER consists of a 10 step control and a continuously variable control, with the step control dial numbers serving as indices for the calibrated variable dial. Those dial readings are added to determine the multiplying number. Since 100 dial divisions are provided for each 10:1 SWEEP TIME range, very accurate indication is obtained and precise resetting made possible.

The overall accuracy of the sweep time calibration is dependent on several factors, including linearity of the sweep amplifier and the cathode-ray tube, but the actual time for an 8 cm sweep will be within +or-5% of the indicated time at any setting of the controls. Somewhat greater accuracy may be expected over the range of .2 microseconds to 5000 microseconds per cm. Provision has been made to compensate for variations caused by different tubes, etc., by screwdriver adjustments inside the case.

Procedure for these adjustments will be found in Section IV.

Due to limitations in 5XP tubes as manufactured at the present time, the horizontal linearity is only good over slightly better than 8 cm of deflection. Therefore to insure accurate readings the measurements should be made in the center of the screen +or-4 cm (8 cm total).

When adjusting the sweep time it is necessary to consider the time relationship between the sweep and the signal under observation. An image of the signal will not appear at all or only a portion of the signal can be seen on a sweep whose duration is less than that of the waveform under observation.

### **RECURRENT SWEEP**

In case it is desirable to have a sweep without using any sort of trigger, merely advance the SWEEP STABILITY control until a stable sweep is obtained. This sweep is the conventional sawtooth variety as used in most oscilloscopes.

### **SINGLE SWEEP**

The triggered sweep circuit used in the Type 513D inherently provides for single sweep operation. The beam is blanked out until the trigger simultaneously turns it on and starts the sweep. For single sweep operation, a mechanical contact or hand key can be connected between the TRIGGER INPUT binding post and ground. If repeated sweeps occur due to intermittent or bouncing contact a capacitor of .1 mf. to 1 mf. should be connected across the contact. This capacitor is charged through 22 megohms and the long time constant prevents an immediate recurrence of the sweep. Use minimum dependable TRIGGER AMPL. setting.

### **SWEEP MAGNIFIER**

Frequently it is desirable to examine in greater detail a portion of the waveshape under observation, for instance the rate of fall of the end of a fairly long pulse. In the Type 513D, the sweep magnifier circuit makes it possible to expand any desired 20% of the sweep to cover the entire tube face. When the SWEEP MAGNIFIER POSITION control is moved from the OUT position, the sweep is delayed for a variable time and then goes at about 5 times its normal rate. The operating procedure is: Turn the SWEEP MAGNIFIER POSITION to OUT. Adjust the sweep



time controls so that the portion of the wave to be magnified is at the right side of the tube. Now turn the SWEEP MAGNIFIER POSITION knob clockwise until the desired signal moves in from the right to the center of the tube face. The magnified sweep is not linear over its entire trace, so it is desirable to use only the center 6 centimeters if possible. If higher magnification than five is wanted, it is only necessary to change plate resistor of V119, R204. A value of 10K will give a magnification of about 10. The somewhat lower resistance chosen appears to be a more usable value in most cases. The SWEEP MAGNIFIER should be turned to OUT position when not in use.

#### **EXT. SWEEP INPUT**

Provision has been made for the connection of external sweep generators to the Type 513D. This might be a sine wave oscillator for frequency comparison, the sweep obtained from a "Frequency sweep" signal generator, an auxiliary slow sweep generator, etc. The EXT. SWEEP INPUT binding post is connected to the horizontal deflection plates via the EXT. SWEEP ATTEN. and a two-stage push-pull Direct Coupled Amplifier. The entire system is DC coupled, permitting the use of very slow sweeps. With the EXT. SWEEP ATTEN. fully clockwise, the deflection sensitivity is approximately 1.5 volts per cm DC or peak to peak AC.

The EXT. SWEEP ATTEN. is combined with the same knob that controls the TRIGGER AMPLIFIER in the Type 513D. This in no way interferes with the operation as these controls are never used at the same time.

#### **DELAY TRIGGER AND GATE GENERATOR**

A delayed gate of approximately 30 volts amplitude is available at the binding post marked DELAY GATE OUT. When the knob marked DELAY TRIG. AND GATE POSITION is turned on this positive going delayed gate may be positioned at any point along the sweep by adjusting the control.

In cases where a trigger of short risetime is desired, a trigger of approximately 50V amplitude (peak) is available at the coaxial connector marked DELAY TRIGGER OUT. This connection is terminated internally with a 4.7 K resistor,

however, for best risetime it should be terminated externally with 100 ohms. The delayed gate and trigger may be used simultaneously if desired as they are both positioned with the same control. When the DELAYED GATE AND TRIGGER are not being used the control should be turned to the OFF position.

The DELAYED TRIGGER AND GATE is only intended for triggering or gating external equipment; however, for testing its operation the waveforms may be observed on the Type 513D by using the 10X probe.

#### **SWEEP OUTPUT**

The SWEEP OUTPUT binding post makes available the waveshape appearing on the plate of the sweep generator tube. A cathode follower is used to isolate the sweep generator from whatever is connected to the SWEEP OUTPUT post. The amplitude is approximately 15V peak.

Inasmuch as the DELAYED TRIGGER AND GATE GENERATOR and the SWEEP LENGTH CONTROL also utilize the sawtooth waveform from this cathode follower (V118A), it is advisable not to place too large a capacitive load on the SWEEP OUTPUT, otherwise it may cause improper operation of these circuits. (Recommended capacity 25 mmfd. ma.).

#### **+GATE OUTPUT**

A cathode follower (V114A) is used to provide a positive square wave gate of the same duration as the sweep. Since this is DC coupled to the sweep generator it provides an accurate square topped pulse even at the longest sweep time.

#### **SWEEP LENGTH CONTROL**

Due to a tendency of the 5XP cathode-ray tubes to "flare" if the electron beam hits the side of the tube, a special circuit has been incorporated into the Type 513D to blank the beam at the end of the sweep so that it will not hit the wall of the tube and cause flare. The point on the sweep at which the beam is blanked is set by the screwdriver adjustment on the side of the case marked SWEEP LENGTH. It should be adjusted so the sweep never quite goes off the screen. This adjustment will in no way change any of the calibrations of the instrument.



# VERTICAL-DEFLECTION SYSTEM

## SIGNAL INPUT CONNECTION

Dual inputs, provided by two UHF connectors, INPUT 1 and INPUT 2, are used in conjunction with the VERTICAL INPUT selector to permit observing either of two separate signal sources without changing connections. This feature allows convenient display of a change in waveform or amplitude between the input and output of a circuit, study of time and amplitude relationships, or observation of other phenomena involving comparison of two different signals.

Normally, signal input connection is accomplished by attaching one of the Type A510 Binding Post Adapters, which are supplied with the oscilloscope, to either INPUT 1 or INPUT 2, and using a standard test lead. When reduced loading on the circuit under observation or exclusion of spurious pickup from stray fields is desired, the Type P510 Input Probe should be used.

The Type P170CF Cathode-Follower Probe is specifically designed for use with the TEKTRONIX Type 517 Oscilloscope, and is not listed in our General Catalogue as a regular accessory. However, this probe can be used within its limitations with the Type 513 and can be purchased separately. Instructions for adapting it to the Type 513 are available, together with a description of its uses and limitations.

## VERTICAL AMPLIFIER

The vertical amplifier of the Type 513D is designed to fully complement the flexible and accurate sweep circuits. Direct coupling and high frequency compensation are employed. The combination of wide bandpass, direct coupling, and high sensitivity is achieved efficiently by the use of a 7-section distributed amplifier in the push-pull output section. Both high-frequency and low-frequency compensation are employed in the pre-amplifier section. The amplifier is adjusted for optimum transient response, so that square-wave pulses and other non-sinusoidal waveforms will be faithfully displayed. Rise-time, from 10% to 90% of full amplitude, is less than .025 microseconds.

The use of the direct coupled amplifier makes it possible to display not only the AC component of a waveform, but also the DC level at which it

occurs. This feature is very valuable in most oscilloscope applications. For example, it is possible to observe when zero bias or grid cut-off occurs, how close to the cathode a plate can swing and many other essential characteristics of circuits. Another advantage of the direct-coupled amplifier as employed in the Type 513D is the ability to utilize the entire undistorted swing in either direction. Thus, the full 4 cm. undistorted deflection is available for pulse display, without recourse to a deflection polarity switch or similar device. To observe positive pulses, set the VERT. POSITION control so that the undeflected (zero signal) trace coincides with the -2 cm. graticule line. For negative pulses, use a +2 cm. setting.

In the interests of simplicity and stability, the sensitivity with direct coupling is limited to .3 volts per cm. This is more than adequate for work in circuits involving vacuum tubes, since signals too small for observation at this sensitivity are also small in comparison with the DC voltages on the tube elements, and thus can be observed without regard to the DC component. Additional gain, achieved by means of a capacitively coupled two stage pre-amplifier, provides a maximum sensitivity of .03 volts per cm for low level circuit work.

Due to the mechanical construction of the vertical deflection plates in the 5XP type of Cathode-Ray Tube, the vertical deflection is limited to slightly more than 4 cm. If we attempt to position the trace beyond this or if the amplitude of the signal is such that it deflects the tube more than this amount, the spot disappears. This in no way indicates a fault in the equipment, but rather is a normal condition with all type 5XP tubes.

## DEFLECTION SENSITIVITY

Continuously variable deflection sensitivity, permitting display of a wide range of signal amplitudes, is achieved by the VERT. DEFL. SENS. control and the VERT. AMPL. ATTEN. The VERT. DEFL. SENS. control performs the dual function of inserting or removing the two stage pre-amplifier and selecting precision frequency-compensated attenuators. Seven steps (two per decade) are provided. The VERT.



AMPL. ATTEN. varies the sensitivity over a 3 to 1 range, filling in between steps of the VERT. DEFL. SENS. control. It is located in a low-impedance cathode-follower circuit to minimize high-frequency discrimination. The overall range of both controls is .03 volts per cm to 100 volts per cm.

### INPUT COUPLING

It is sometimes unnecessary or undesirable to display the DC level of a waveform. For example, in measuring the ripple on a DC supply, the sensitivity required to adequately present the ripple voltage would usually cause the DC component to exceed the range of the vertical position control. The AC-DC selector permits optional capacitive coupling in the range of .3 volt per cm to 100 volts per cm. Capacitive coupling only is available in the range of .03 volt per cm to .3 volt per cm.

### SIGNAL DELAY

Approximately .1 microsecond is required, after receipt of a sharp trigger impulse, for the sweep to become linear and to unblank the cathode-ray tube. Therefore, unless the waveform under observation is recurrent during the period of the sweep, the first .1 microsecond will not be displayed. In the Type 513D, a 40 section network inserts a signal delay of .25 microsecond, so that the sweep is well underway before the initiating waveform appears on the CRT.

### DIRECT CONNECTION TO DEFLECTION PLATES

To allow direct connections to be made to the deflection plates with the lowest possible capacitance a removable access panel is provided in the side of the case of the Type 513D. This panel is split in two sections with two wire guides machined at the junction. This will allow the deflection plate leads to be supported away

from the case and prevent changes in capacitance between these wires. The internal connecting clips are color coded, also the shield is marked with the same color close to the connections on the neck of the tube. D1 and D2 are the horizontal deflection plates coded Brown and Red. A2 is Anode No. 2 connection coded Green. D3 and D4 are the vertical deflection plates coded Orange and Yellow.

Deflection sensitivity is approximately 17 volts DC per cm (+or-15%) on the vertical plates and 50 volts DC (or peak-to-peak AC) per cm (+or-15%) on the horizontal plates. A positive voltage on D3 causes upward deflection, a positive voltage on D2 causes a deflection to the right.

If direct connection to only one set of deflection plates is desired, it is important to maintain the correct average potential to prevent defocussing of the CRT spot. The average potential of the vertical deflection plates (measured from the chassis) is approximately 200 volts, and this same value should be used on the horizontal plates when they are used for direct connection.

Adjustment of the average potential of the horizontal deflection plates from approximately -25 volts to +225 volts is provided by R170 and R171 (marked ADJUST D1 and ADJUST D2) located on the sweep chassis (screwdriver adjustments). After making a direct connection to the vertical deflection plates (D3 and D4), the average potential of the horizontal plates should be adjusted to correspond. See Section IV, ADJUSTMENT SWEEP, DC OUTPUT LEVEL.

**CAUTION** --BE SURE TO READJUST R170 and R171 (D1 ADJUST and D2 ADJUST) when normal internal deflection plate connections are restored. Also readjust -2000 volts, if its setting has been changed, as outlined in Section IV.





# SECTION 3

## CIRCUIT INFORMATION

### BLOCK-DIAGRAM

The Block Diagram of the TEKTRONIX Type 513 Oscilloscope shows the major units and pertinent waveforms present at various portions of the circuit.

The diagram as shown has the trigger selector switch in a position to accept external triggering. The trigger inverter supplies a positive trigger signal to the trigger amplifier regardless of the input polarity to the inverter. The trigger amplifier applies an amplified negative signal to the multivibrator and triggers it. The coupling diode couples the amplifier and multivibrator together during the negative trigger signal and then disconnects them as soon as the multivibrator is tripped. The multivibrator gates the sweep generator and also generates an unblanking signal for the cathode-ray tube. The sweep-generator signal is amplified in a cathode-coupled phase-inverter amplifier which drives the push-pull output sweep amplifier coupled to the horizontal plates of the cathode-ray tube. The dc level adjusters permit the dc level of the horizontal deflection plates to be set properly while not deteriorating the sweep sawtooth waveform.

The sweep magnifier, when switched into the sweep circuit, amplifies the sweep generator output by a factor of five to speed the sweep. By means of a biasing adjustment, the level at which output from the magnifier begins can be adjusted so that any portion of the sweep can be magnified.

The unblanking amplifier amplifies the signal from the negative-going half of the multivibrator and applies it to the cathode-ray tube control grid through a cathode-follower amplifier, so as to turn on the cathode-ray beam during the period of the sweep. The blanking multivibrator signal overrides the unblanking multivibrator signal at the appropriate time when the sweep has just completed. The blanking multivibrator is timed

by means of a bias arrangement in conjunction with the external sweep output sawtooth voltage.

The sweep output cathode follower also couples into the bistable multivibrator comparator through a cathode follower impedance converter to provide a delayed gate output. The leading edge of the delayed gate signal is differentiated in the differentiating network and applied through the cathode follower to trigger the blocking oscillator. The output of the blocking oscillator is available through a cathode follower at a front-panel connector as a delayed trigger signal. The timing of the delayed gate and trigger is adjustable by means of a biasing arrangement of the bistable multivibrator comparator, so as to occur at any desired point on the sweep.

The vertical input selector switch is shown in a position to accept external signals. The input attenuator provides several ratios of attenuation. The input preamplifier is switched out except in the two most sensitive positions of the vertical input sensitivity switch. An internally-derived trigger signal is provided by amplifying a portion of the output of the gain-control cathode follower. The delay network provides enough signal delay to permit the sweep to get underway before the signal appears at the vertical deflection plates. The cathode follower transforms impedance level to match the delay network input impedance.

The driver amplifiers are cathode coupled to provide phase inversion for the push-pull distributed output amplifiers. The output amplifiers drive the vertical deflection plates of the cathode-ray tube.

The calibrator multivibrator provides a square-wave voltage through the limiter cathode follower to a calibrated voltage-divider network. The limiter cathode follower is adjustable to



provide an accurate voltage level to the input of the calibrated voltage divider. The vertical input switch selects various voltage levels from the voltage divider and applies them either to the vertical amplifier, or, in two switch positions,

applies them to a front-panel connector.

The individual circuits of the TEKTRONIX Type 513 Oscilloscope are described in the pages following.

## HORIZONTAL-DEFLECTION SYSTEM

### TRIGGER PHASE SPLITTER

The TRIGGER SEL. switch operating in conjunction with V101, the trigger phase splitter, selects the source of trigger signal, and reverses its phase if necessary, to supply the required positive signal to the grid of trigger amplifier V103. When the TRIGGER SEL. switch is in the -SIG. RATE GEN., 60 c.p.s. or +EXT. positions, signals are taken off the cathode of V1 and do not change in polarity. Therefore a positive impulse must be supplied either by an external source or by the signal under observation through the vertical amplifier. With the TRIGGER SEL. switch in the +SIG. or -EXT. positions, signals are taken from the plate and are therefore reversed in polarity, thus providing the required positive output from negative trigger sources. V102A is a dc restorer which prevents the grid of V103 from going more negative than the bias level.

### TRIGGER AMPLIFIER

The 6AG7, V103, is a variable-gain amplifier for the positive trigger impulses received from V101. The TRIGGER AMPL. potentiometer, R113, varies the bias and thus determines the gain of V103. R112 in the cathode of V103 protects the tube from excessive cathode current in the event of misadjustment of R113.

### TRIGGER COUPLING DIODE

The negative trigger impulses from the plate of V103 are impressed on the plate of the negative-going multivibrator, V104, by means of the coupling diode, V102B. The diode disconnects the trigger amplifier from the multivibrator plate as soon as this plate goes negative with respect to V103 plate. The amplifier and multivibrator remain disconnected until the completion of the cycle when the multivibrator plate again goes positive and is ready to be triggered again.

### TRIGGER RATE GENERATOR

The trigger rate generator consists of a blocking oscillator, V507, and the cathode followers, the two halves of V508. The TRIGGER RATE GEN. switch selects R529 to R533, which, with C512, determine the repetition rate. The output goes to the RATE GEN. OUT binding post on the front panel via the cascaded cathode followers consisting of the two halves of V508. The cathode followers provide a low-impedance output source which can work satisfactorily into external resistance loads as low as 75 ohms, or into comparatively large capacitance loads without undue deterioration of the sharpness of the trigger pulse.

### MULTIVIBRATOR

A multivibrator is provided to convert the various shapes of trigger impulses into square waves of controllable duration, suitable for operating the sweep generator and for unblanking the cathode-ray tube. The multivibrator consists of the negative-going section, V104, a 6AH6, and the positive-going section, V105, a 6AG7. During the waiting period, V105 is fully conducting because its grid is at cathode potential. Its plate is therefore at low potential because of the drop in the plate load resistor, R123. With the plate of V105 at low potential and the SWEEP STABILITY control properly adjusted, the grid of V104 is held below cut off by voltage divider R117, R118. The circuit remains in this condition until a trigger impulse is received. The plate of V104 is driven down by the trigger pulse as is also the grid of V105 through timing capacitor C104, C105, C106, or C107. The plate of V105 therefore rises, carrying with it the grid of V104, causing V104 to conduct more and more until V104 conducts fully and V105 is cut off. This condition lasts until the timing capacitor discharges far enough to raise V105 grid into the plate current conducting region, whereupon V105 plate falls carrying V104 grid with it and V104 is once more cut off. This is the condition that



existed before the trigger impulse was received. The plate of V105 produces a positive square-top pulse while the plate of V104 produces a negative one.

The positive pulse is brought out to a binding post on the front panel, labeled +GATE, through cathode follower, V114A. The negative pulse is used to control the operation of the sweep generator and to initiate the unblanking pulse.

The duration of the pulse depends on the length of time V105 is cut off, which in turn depends on the RC time constant of the timing capacitor (C104 to C107) and the timing resistor (R120 plus R121 plus R122A), and is substantially independent of the shape or amplitude of the triggering pulse. Variation of the pulse duration is provided by selection of timing capacitors, C104 to C107, on SWEEP RANGE switch SW102, and variation of timing resistors, R121 and R122A, to vary the time constant. R121 is a step switch calibrated in units of one, providing equal steps of resistance, and R122A is continuously variable and calibrated in tenths. Capacitor switch SW102 is calibrated in powers of ten from 0.1  $\mu\text{sec/cm}$  to 1000  $\mu\text{sec/cm}$ . The time constants selected provide a multivibrator pulse duration about twenty per cent longer than the time required for the spot to traverse the cathode-ray screen at each sweep speed.

## UNBLANKING

During the waiting period between sweeps, the cathode-ray beam is cut off by negative voltage on the control grid. Unblanking is initiated by the negative pulse from the plate of V104. The pulse is shaped and amplified by V115, then fed to the cathode follower, V116, which provides a low-impedance output source for the unblanking pulse.

Because of a tendency of 5XP cathode-ray tubes to flare if the beam strikes the side of the tube, a special circuit has been added in the Type 513 oscilloscope which blanks off the beam just as it reaches the end of the sweep, and thus prevents flare from occurring. The circuit consists of V117, a 12AT7, as a cathode-coupled bistable multivibrator which is tripped when the sweep output from cathode follower V118.1 reaches a value determined by the setting of R194, a screwdriver adjustment, labeled SWEEP LENGTH ADJ. At the time that V117 trips over, it generates a positive pulse that is applied

to one of the grids of V115. This pulse effectively cancels the negative unblanking pulse from V104 and drives the grid negative on the unblanking cathode follower, V116, thereby cutting off the cathode-ray beam at a time, determined by the setting of R194, just before the beam reaches the wall of the tube.

## +GATE CIRCUIT

V118.1 is a cathode follower which permits the positive pulse from the multivibrator to be brought out to a terminal on the front panel, labeled +GATE, at low impedance.

## SWEEP GENERATOR

The sweep generator, V106, is held in a highly conducting condition during the quiescent period between sweeps by the positive bias from voltage divider R128, R129. A sharp negative pulse from the plate of V104 cuts off V106, and the selected timing capacitor, C112 to C117 begins to charge through R139, R121.1 and R122 from the constant-voltage source, V107. Accuracy of the sweep speed is maintained by charging the timing capacitor from a constant-voltage low-impedance source. Linearity of the sweep sawtooth waveform is obtained by using only the first ten per cent or less of the exponentially-rising charge voltage. When the multivibrator returns to the quiescent state, the positive pulse that occurs at the plate of C104 raises the grid of V106 positive, the plate of V106 drops almost to ground, and the timing capacitor discharges ready for the next sweep.

## SWEEP MAGNIFIER

The sweep magnifier V119, delays the start of the sweep by an adjustable period of time and then causes the sweep to go at five times its normal speed except at the fastest sweep speed. The delay is accomplished by setting the bias voltage on R206, labeled MAGNIFIER POSITION, to the proper level so that conduction does not begin until the desired percentage of the sweep sawtooth time has passed.

The bias voltage variation available by adjustment of R206 is sufficient to permit starting the magnified sweep at any part of the normal sweep. V118.2 is a dc restorer which starts the magnified sweep at the same potential each time so as to stabilize the trace.



## **SWEEP AMPLIFIER**

The signal from the sweep generator, V106, is impressed on the grid of V109A, a cathode-coupled amplifier which inverts phase and operates in push-pull in conjunction with V109B. Their output voltage is further amplified in V110 and V111 which operate into 25 kilohm loads. Degeneration is provided by R157 and R158 to improve linearity. The horizontal deflection plates of the cathode-ray tube must operate at the same dc voltage as the vertical deflection plates to avoid defocusing. The vertical deflection plates operate at 200 volts because of the dc coupling of the vertical amplifiers, so level-setting tubes, V112 and V113 provide an adjustable dc level in this range for the horizontal plates. Adjustment of this dc level is provided by screwdriver adjustments R170 labeled D1 ADJUST, and R171.1 labeled D2 ADJUST.

The dc level setting tubes permit the current through dropping resistors R166 and R167.1 to be varied while maintaining such a high plate resistance that their shunting effect across the deflection plates is negligible. Plate current is varied by varying the resistance in the cathode circuit which varies the grid-to-cathode voltage. The plate resistance is kept high by means of the neon glow lamps between cathode and screen which maintain the cathode-to-screen voltage constant.

## **DELAYED GATE AND TRIGGER**

The positive-going sweep signal is introduced to a bistable, cathode-coupled multivibrator, V501, from the cathode of V118.1, the SWEEP OUTPUT cathode follower. When the sweep voltage reaches a voltage determined by the setting

of R501, the multivibrator is triggered and the voltage of the second plate, pin 6 of V501, rises rapidly carrying with it the grid of V502. V502 is a cathode follower whose output is connected to a front-panel binding post labeled DELAY GATE OUT. When the sweep voltage drops back to zero at the end of the sweep, V501 reverts to the quiescent condition with the second plate, pin 6, of V501 conducting and at low voltage. With this plate at low voltage, cathode-follower V502 is approximately cut off; with the plate of the multivibrator not conducting and at high voltage, the grid of the cathode follower is raised to about 30 volts positive. A square top gate therefore appears at the DELAY GATE OUT terminal with an amplitude of about 30 volts and a duration equal to the time that pin 6 plate of V501 is not conducting.

The positive cathode pulse from V502 is differentiated through C505 and applied as a sharp spike to the grid of the other half, also a cathode follower with cathode connected to the cathode pin 8, of V503, part of a blocking oscillator. This half of V503, when conducting keeps the blocking oscillator from oscillating. The positive spike from V502 on the cathode of V503 cuts off plate current from the plate, pin 6, and the blocking oscillator generates a positive pulse. Before the blocking oscillator is ready to generate a second pulse, the cathode spike has passed and plate current again flows in the plate, pin 6, of V503, and oscillation of the blocking oscillator is stopped.

V504 is a cascaded cathode follower driven by the pulse-output winding of the blocking oscillator transformer, T501, which supplies the generated pulse to a coaxial front-panel connector labeled DELAY TRIG. OUT, for connection to an optimum impedance of about 100 ohms.

## **VERTICAL-DEFLECTION SYSTEM**

### **VERTICAL INPUT**

The VERTICAL INPUT switch, SW1, in its first two positions selects either of two coaxial front-panel connectors labeled INPUT 1 and INPUT 2, and connects them to the vertical amplifier system. In the next seven positions, SW1 selects a calibrating square wave voltage between 0.05 volts and 50 volts, peak to peak, and connects it to both the vertical amplifier system and to CAL OUTPUT front panel connector. In the

last two positions, labeled TEST 5, and TEST 50, SW1 connects either 5 volts or 50 volts of calibrating voltage to the CAL OUTPUT front-panel connector, and at the same time connects INPUT 1 front-panel coaxial connector to the vertical amplifier system. With this arrangement, the probe cable can be connected to INPUT 1 and the probe can then be touched to the CAL. OUT terminal to obtain two accurate voltages for adjusting the probe.



## CALIBRATOR

The calibrating voltage generator consisting of a multivibrator, V509, a 12AU7, operating at a frequency of about 1000 cycles, generates the calibrating square wave. V510, a second 12AU7, is a wave shaper and cathode follower. R557, a screwdriver adjustment labeled CAL. ADJUST, sets the bias for the diode-connected portion and thereby limits the positive swing of the grid of the cathode-follower section.

In the intermediate seven positions of the VERTICAL INPUT switch, SW1, a voltage picked off of a tapped voltage divider, R542 to R548, in the cathode circuit of V510, is applied to a calibrated continuously-variable potentiometer, R541, labeled CAL. VOLTAGE, whose arm is connected to the CAL OUT terminal.

## VERTICAL SENSITIVITY

A seven-position switch SW2, labeled VERT. DEFL. SENS., arranges the input circuits to the vertical deflection system for seven fixed sensitivities. In the two positions of highest sensitivity, .03 volts per cm, and .1 volt per cm, a preamplifier with a gain of ten times is connected into the system. The pre-amplifier consists of two ac coupled type 12AW6 pentodes, V1 and V2, with shunt and series of high-frequency peaking inductors and V3, a 12AT7 cathode follower impedance converter to minimize the effects of switch capacitance. The preamplifier extends the rise time very slightly, probably 0.001 or 0.002  $\mu$ sec.

In the third position of SW2, the input is connected directly to the vertical deflection system with no attenuation. In all other switch positions except the first and third, resistor-capacitor voltage-divider attenuators are selected to provide the five additional fixed sensitivities. When the probe is used, an additional ten times attenuation results. The probe resistor forms the series arm of a voltage divider, the shunt arm of which is the input network at each of the switch positions. V4, a 12AT7 cathode follower, feeds R49, a 1-k potentiometer labeled VERT. AMPL. ATTEN. The adjustable output of this attenuator potentiometer is applied to a second cathode follower 12AT7, V7, which feeds the 1/4-microsecond, 300-ohm delay line, through an RC network, R36, R37, C28.1, and C28.2, which improves the transient response. R50, a screw

driver adjustable 10k resistor labeled C.F. ADJ. adjusts the dc voltage at the cathode of cathode-follower V4 so that it is at the same potential as the top of potentiometer R49 at its junction with R45. When this adjustment is correctly made, no shift of the trace will occur with change in the vertical attenuation position.

The delayed output from the delay line drives four 6AH6 pentodes, V9, V10, V11, and V12 in a push-pull parallel common-cathode phase-inversion driver amplifier. Vertical positioning is accomplished by adjusting the dc voltage of R58 which sets the dc level of the grids of V10 and V12 of the phase-inverted half of the driver amplifier.

## DISTRIBUTED AMPLIFIER

The grid lines of the distributed amplifier are fed at a midsection to avoid adding reactance to the plate load of the drivers, V9 to V12. The lines are terminated at each end in 670 ohms. The grids of V15 to V28 are fed successively by the signal as it travels down the grid lines. The amplified signal appearing at each plate moves in both directions, and the portion of the signal going in the forward direction is reinforced at each tube, so that the total gain is the sum of the individual tube gains. The available voltage at the cathode-ray tube is doubled by omitting terminating resistors at the forward end of the plate line. The combination of L13 and L94 compensates for the reactance of the deflection plates of the cathode-ray tube. The portion of the signal going in the reverse direction is dissipated in the plate-line termination resistors, (R88 to R89.2 and R90 to R91.2 below SN 1407; R88 and R90 above SN 1408).

At SN1407 dc shift compensation network was added to compensate for certain defects which seem to occur in the tube cathode circuits. The operation of this circuit is described as follows: Screwdriver adjustable R89, labeled DC SHIFT COMP, is bypassed by C88 and C90. The time constant of the network is about a half second. Current through it can be adjusted by varying R89 so that it produces an effect equal and opposite to the dc shift in the amplifier tubes V15 to V22. The effect of the compensation is to reduce the gain slightly by reducing the termination resistance for the first half second of a sustained signal.



## POWER SUPPLIES AND CRT

### POWER SUPPLY

The negative 140-volt supply is stabilized by an OD3 gas regulator tube supplied with a nominal 300 volts through dropping resistor R428 from the unregulated negative-300-volt bus. V411.1 and V411.2, two 6X4 full-wave rectifiers, rectify the 60 cycle ac current from terminals 24 and 25 of transformer T401.

The positive 225-volt supply receives rectified current from terminals 24 and 25 of T401 through selenium rectifiers SR2 and SR3. This rectified voltage is regulated by comparing the voltage of a type 5651, 80-volt, gas regulator tube to the voltage near 80 volts of a divider, R424, R425, R426, connected between the +225-volt bus and ground. The error signal is amplified in V409 and again in V408 and applied to the grids of series regulator tube V407, two halves of a 6AS7 in parallel. R413.1 and R413.2 increase the current capacity of the regulated portion of the supply. An unregulated tap at 330 volts nominal bypasses V407.

The +275-volt supply obtains its dc current from selenium bridge rectifier SR1 which is added to the unregulated +330-volt bus. The rectified voltage is regulated by comparing to ground potential the voltage of a voltage divider, R411, R412, connected between the +275-volt bus and the stabilized---140-volt bus. The error voltage is amplified in V406 and applied to the grid of V405, a 6AU5 series regulator tube.

The +800-volt supply obtains its dc current from a voltage doubler circuit with V401 and V402, added to the 2330-volt unregulated bus. This voltage is regulated by comparing to regulated +225-volts, the voltage near 225-volts on a divider, R403, R405, connected between the +800-volt bus and ground. The error voltage is amplified in V406 and applied to V403, a triode-connected 6AS5 series regulator.

### HIGH VOLTAGE POWER SUPPLY

The accelerating voltage for the cathode-ray tube is supplied by an oscillator, voltage-tripler circuit. V415 is the oscillator which uses the primary winding of T402 as the tuned circuit.

The rectified voltage is regulated by comparing a portion of the negative supply from V418.1 with the regulated negative 140-volt bus. The error voltage is amplified in V415 and applied to series regulator tube V413 which controls the plate voltage of the oscillator.

R441 labeled ADJ-20000, a 2-megohm potentiometer, bridges the shunt leg of voltage divider R450, R450.1, to provide a means of adjusting the high voltage. Voltage divider R434, R435 adjusts the heater of V413 to approximately the same voltage as its cathode.

### CATHODE-RAY TUBE CIRCUITS

The TEKTRONIX Type 513 oscilloscope is equipped with a 5XP cathode-ray tube. This tube has a 5-inch fluorescent screen with electrostatic focus and deflection. Three steps of post accelerating potential are used to provide high spot intensity. The total accelerating potential is 12-kv (2-kv negative and 10-kv positive), producing a sharp, bright image at the fastest sweeps. The high image brightness is particularly useful where single high-speed sweeps are photographed.

The various cathode-ray tube voltages are furnished by the voltage-stabilized power supply previously described.

V114 is a cathode follower voltage divider which provides a low impedance adjustable voltage source for anodes A2 to provide astigmatism adjustment.

Cathode voltage of the cathode-ray tube is stabilized by means of three neon glow lamps connected between the -2100-volt bus and the cathode. R212, a 2-megohm potentiometer connected across the three neon glow lamps provides an adjustable grid-to-cathode voltage adjustable by means of a front-panel control labeled INTENSITY.

The focusing anode voltage is adjustable by means of potentiometer R210, a part of voltage divider string R209, R210, R211 between cathode voltage and ground. The potentiometer has a front-panel control labeled FOCUS.



# SECTION 4

## MAINTENANCE

### GENERAL INFORMATION

#### VENTILATION

Care must be taken to assure free ventilation of the unit inasmuch as some of the components are operated at dissipation levels such that excessive temperatures will result without adequate air circulation.

To assure free passage of air, units should be placed so that the air intakes are not placed by other apparatus or furniture, and the filters should be kept clean.

A washable Lumaloy Air Filter is used at the air intake port of the unit. The following filter cleaning instructions are given by the filter manufacturer:

#### " TO CLEAN:

- (1) If grease or dirt load is light, remove filter from installation and flush dirt or grease out of filter with a stream of hot water or steam.
- (2) If load is too heavy for treatment in (1) above, prepare mild soap or detergent solution in pan or sink deep enough to cover filter when laid flat. Agitate filter up and down in this solution until grease or dirt is loosened and carried off filter.
- (3) Rinse filter and let dry.
- (4) Dip or spray filter with fresh Filter Coat, or other approved adhesive. Filter Coat is available from the local representative of RESEARCH PRODUCTS CORP. in the one-pint Handi-Koter with spray attachment or one-gallon and five-gallon containers."

#### REPLACEMENT OF COMPONENTS

Most of the components used in the construc-

tion of TEKTRONIX instruments are standard parts obtainable from any well-stocked parts distributor. Some of the components carrying 1% and 2% tolerances may not be so readily obtainable but may be purchased from the manufacturer at these tolerances. The remainder of the low-tolerance components are standard 10%- and 20%-tolerance parts that are checked at the factory for proper value or performance. Replacement parts are available on order from the factory at current net prices but in the case of standard parts it is probably more economical of time to purchase them locally. It is not feasible to attempt to check out low-tolerance parts or matched pairs without a reasonably large stock to choose from as the rejection percentage is quite high in most cases.

A TEKTRONIX instruction manual will usually contain hand-made changes of diagrams, parts lists, and text, appropriate only to the instrument it was prepared for. There are good reasons why this is true.

First, TEKTRONIX engineers are continually working to improve TEKTRONIX instruments. When the improved circuitry is developed or when better components become available, they are put into TEKTRONIX instruments as soon as possible. As a result of constant improvement TEKTRONIX instruments are always built as good as we can build them, but the changes caused by these improvements must frequently be entered by hand into the manual.

Second, when TEKTRONIX instruments go through our exhaustive test procedure, TEKTRONIX technicians adjust them individually to obtain optimum operation. This kind of hand tailoring occasionally requires substitution of components differing from the nominal values printed in the manual.



Third, because of procurement difficulties, equivalent but different parts are sometimes used. Usually such parts are directly interchangeable with those originally specified. No alternate parts have been used which have adversely affected the instrument, and you were able to receive your instrument much earlier than you might have otherwise.

To assure that you will receive the correct replacement parts with the minimum of delay it is therefore important that you include the instrument serial number with your order, along with the instrument type and part numbers, of course. And as a further precaution, get ordering information from the instruction manual whose serial number agrees with the instrument.

Equivalent parts, supplied by the factory when

the exact replacement parts ordered are not available, will be accompanied by an explanation and will be directly interchangeable in most cases.

#### REMOVAL OF THE CASE

Set the oscilloscope face downward on a padded flat surface, remove the two screws in the bottom, then lift off the case.

**CAUTION** VOLTAGES HIGH-ENOUGH TO BE DANGEROUS ARE PRESENT IN THIS INSTRUMENT. SINCE MUCH MAINTENANCE MUST OF NECESSITY BE PERFORMED WITH THE CASE REMOVED, GREAT CARE SHOULD BE TAKEN. USE ONLY INSULATED TOOLS, STAND ON A DRY FLOOR, AND IF POSSIBLE KEEP ONE HAND IN YOUR POCKET.

## POWER SUPPLY

### OPERATION ON 210-250 VOLT LINE

The power transformer of the Type 513D is wound with two 115 volt primaries. When the instrument leaves the factory, the primaries are ordinarily connected in parallel for 105-125 volt operation. If operation from 210-250 volt lines is desired, remove the jumpers connecting 1 to 2 and 3 to 4. Now connect terminals 2 and 3 together. With the line still connected to terminals 1 and 4, the instrument is ready for 210-250 volt operation.

The fuse normally supplied when the Type 513D is wired for 105-125 volt operation is 6 amp, 250 volt slo-blo. For proper protection on 210-250v operation this fuse should be changed to 3 amp 250 volt slo-blo.

### OUTPUT VOLTAGES

The output of the +800V supply as well as the DC filament voltages for the vertical amplifier are dependent on the output of the +225 volt supply. In order for the instrument to perform properly, it is necessary that the +225 volt supply be within plus or minus 5 volts of that value. This should be checked with an accurate voltmeter and corrected if necessary by adjustment of potentiometer R425 on the sweep and power supply chassis marked +225 (screwdriver adjust). This check should always

be made if the 5651 tube (V410) is changed.

The calibration of the SWEEP TIME and the VERT. DEFL. SENS. are dependent on the acceleration voltages applied to the CRT. If it is suspected that the calibration is off, the ---2000 volt supply should be checked with an accurate meter of at least 20,000 ohms per volt and adjusted if necessary. A rough check can be made by measuring from the terminal on the Type 210 high voltage power supply marked --21.KV to ground. This should read between ---2000 volts and ---2100 volts. For accurate setting of this voltage, the reading should be taken from the cathode of the CRT and the anode A2. The cathode of the CRT is available on the focus, intensity board. The A2 connection is the center terminal on the neck of the CRT (coded green). The oscilloscope should be operating with the focus, intensity and astigmatism at proper settings. The screwdriver adjustment, marked ---2000V should be adjusted to this reading.

**CAUTION** -EXTREME CARE SHOULD BE TAKEN IN MAKING THIS ADJUSTMENT AS THE VOLTAGES INVOLVED ARE HIGH ENOUGH TO BE DANGEROUS TO LIFE. IT IS SUGGESTED THAT ALL CONNECTIONS BE MADE WITH THE POWER OFF.





## SWEEP CIRCUITS

### SWEEP AMP. CONTROL

To insure the most linear operation of the sweep amplifier output tubes (V110 and V111) the operating currents should be held to rather close limits. Due to the direct coupling between the driver stage (V109) and the output, slight changes in tube characteristics will greatly change the current drawn by the output stage, thereby changing its operating point. To compensate for tube and circuit variations a screw-driver adjustment, R144 marked SWEEP AMP., is provided. This changes the cathode current of V109 and thereby changes the plate current of the output amplifier (V110 and V111). In event that any of the tubes in the sweep amplifier are changed, it is wise to recheck this adjustment. This should be done as follows: The SWEEP STABILITY control and the TRIGGER AMP. control should be turned counter-clockwise, stopping the sweep. The HOR. POSITION control should be turned all the way clockwise, which should position the spot near the center of the screen. The voltage at the plates of the 6AQ5 sweep output tubes (V110-V111) should be checked with an accurate voltmeter of at least 1000 ohms per volt. The voltage should read approximately 390 volts to ground (+or-5%). A slight adjustment of the HOR. POSITION control should bring the voltage at the two plates to the same reading. If it is impossible to bring the voltage to the same value it would be wise to replace either the driver tube (V109) or the output tubes (V110 and V111).

The SWEEP AMP. control (R144) should be adjusted to give an average voltage on the output tube plates of 390 volts. (After making this adjustment, the controls should not be moved until the D.C. output level is adjusted as outlined below.)

### D.C. OUT PUT LEVEL

To obtain proper CRT focus, the average potentials of the horizontal and vertical deflection plates must be approximately equal. Because of the direct coupling, the potential of the vertical deflection plates is determined by the vertical amplifier. The D.C. level controls (marked D1 ADJUST and D2 ADJUST) provide a

means for setting the average horizontal plate potential to the same value as the vertical plates.

With the sweep OFF, and with the HOR. POSITION control adjusted to give equal voltage of approximately 390 volts on the plates of the sweep output tubes as outlined above, the voltage at the CRT deflection plates D1 and D2 should be adjusted by means of R170 (D2 ADJUST) and R171 (D1 ADJUST) to exactly +200 volts each as measured with a V.T. Voltmeter or a D.C. Voltmeter of at least 20,000 ohms per volt (+200 volts is the average D.C. potential of D3 and D4 when used with the internal vertical amplifier.)

In the event that external equipment is used to deflect the trace in the vertical direction, the average D.C. voltage applied to the vertical plates (D3 and D4) should be determined and the D1 and D2 adjustment should be set to give that reading.

If the sweep calibration is important and the Type 513D is to be used with external vertical deflection it is advisable to readjust the ---2000 volt acceleration potential (as outlined in Section IV, POWER SUPPLY), after the D.C. OUTPUT LEVEL is adjusted as outlined above. The reason for this is that with a new average D.C. level on the deflection plates, the ASTIGMATISM control will require a new setting for best focus. The ASTIGMATISM control changes the anode potential (A2) on the CRT and thereby slightly changes its sensitivity which in turn changes the SWEEP TIME calibration. If an error of 5 to 10% can be tolerated there will be no need to readjust the ----2000 V acceleration potential.

### TIMING SERIES CAPACITORS

If it is ever necessary to replace one of the timing-series capacitors (C114, C115, C116, C117) it is suggested that all four capacitors be obtained from TEKTRONIX, INC., and be replaced as a group. When ordering replacement parts be sure to mention instrument type and serial number.

The timing series consists of one group of four capacitors arbitrarily chosen from the six possible series shown below.



Nominal Value	SERIES					
	1-J	1-K	1-L	1-M	1-N	1-P
1 $\mu$ f	.95	.96	.97	.98	.99	1.0
.1 $\mu$ f	.097	.098	.099	.10	.101	.102
.01 $\mu$ f	.0097	.0098	.0099	.010	.0101	.012
1000 $\mu$ f	890	900	910	920	930	940

The values shown are minimum with a tolerance of-----0 to+1%.

### SWEEP TIME CALIBRATION

If the Cathode-Ray tube is replaced, or if the Sweep Amplifier tubes V110, V111, or V112 are changed, the indicated sweep time may be in error. This may be corrected by adjustment of the potentiometer marked SWEEP TIME (R136) (screwdriver control), for all ranges except the .1 to 1  $\mu$ sec per cm range, which is corrected by varying C112 located on the rear section of the SWEEP TIME switch.

These adjustments may be made with the aid of an accurately calibrated oscillator. A commonly available instrument suitable for this purpose is the Army Frequency meter BC221, or the Navy equivalent, Type LM. If this type instrument is

used, set the frequency at 200KC and connect it to the Type 513D SIGNAL INPUT. With the SWEEP TIME MULTIPLIER at 5.0 and the SWEEP TIME at 1.0 microsecond per cm adjust R136 (screwdriver control labeled SWEEP TIME) until 1 cycle coincides with 1 cm of the scale or that 8 cycles coincides with 8 cm. (NOTE--Use only the center 8 cm of the scale for these adjustments as there may be non-linearity beyond this area.)

Change the frequency meter setting to 2 mc., set the SWEEP TIME at .1 microsecond per centimeter and the SWEEP TIME MULTIPLIER at 5.0.

Adjust C112 (located on the rear section of the SWEEP TIME switch) until 1 cycle equals 1 cm or 8 cycles equals 8 cm of deflection. In case the sweep seems to be too fast or too slow at the start this may be corrected by an adjustment of C122 (located on the vertical board above the sweep amplifier tubes). As these two adjustments interact to some extent C112 should be readjusted every time C122 is changed.

**NOTE** ----Use the minimum TRIGGER AMPL. setting consistent with a stable pattern.

### CALIBRATOR CIRCUIT

It is necessary that the maximum output of the square wave calibrator be accurately set to coincide with the dial calibration in order to maintain the accuracy of the CAL. VOLTAGE control. A convenient method to make this calibration is as follows:

1. The VERT. DEFL. SENS. switch should be set on the .3 to 1 range.
2. The VERTICAL INPUT should be set to 50 volt CAL. RANGE.
3. The CAL. VOLTAGE should be set full counterclockwise.
4. The CAL. VOLTAGE control should be carefully advanced until the image of the calibrator just appears on the CRT screen. If necessary, the knob should be loosened and readjusted so that the electrical zero and the ZERO marking on the scale coincide.
5. A comparison between the calibrator output and a known DC voltage should be made. A suggested DC source is a 45 volt "B" Battery and an accurate 50 volts scale DC voltmeter. As an example, assume that the meter indicates a battery potential of 47 volts. Position the CRT trace at --2 cm. With the vertical deflection sensitivity set for approximately 15 volts per cm and with the AC-DC selector set at DC, connect the battery (with voltmeter connected), to either INPUT 1 or INPUT 2 and note the deflection produced. Switch the VERTICAL INPUT selector to 50V CAL. RANGE with the CAL. VOLTAGE set at 4.7 (47 volts). Compare the calibrating voltage with the former deflection, and if necessary adjust R557, labeled CAL. ADJ., located at rear of vertical amplifier chassis until equal deflections are obtained.



## VERTICAL AMPLIFIER

Note--A warm-up period of approximately 30 minutes to stabilize the characteristics should precede adjustment of the vertical amplifier.

### VERTICAL POSITION ADJ.

The range of the front panel VERT. POSITION control may be adjusted by means of R59 (marked VERT. POS. RANGE in earlier instruments and VERT. POS. ADJ. in later instruments), located on the right side of the oscilloscope. With the front panel VERT. POSITION control centered (index mark vertical) adjust R59 until the CRT trace is centered vertically.

### CATHODE FOLLOWER BALANCE

R50 (labeled C.F. ADJ.) located on the right side of the oscilloscope should be adjusted so that varying the setting of the VERT. AMP. ATTEN. does not shift the vertical position of the trace. If considerable adjustment is required, it may be desirable to recheck the range of the VERT. POSITION control.

### PREAMPLIFIER L.F. RESPONSE

Since electrolytic capacitors are employed in the preamplifier low frequency compensation circuit, it may be occasionally necessary to correct for a change in their capacitance. This is easily done by adjusting R25 (labeled L.F. ADJ.) while observing the response to a low frequency square wave (30 to 60 cycles). The Tektronix Type 104A and Type 105 Square Wave Generators provide a suitable signal. The VERT. DEFL. SENS. control may be in either the .03 to 0.1 or the 0.1 to 0.3 volts per cm position.

### INPUT ATTENUATOR AND PROBE

The various attenuators in the Type 513D are of the RC type in which the resistor divider ratio is equal to the capacitor divider ratio and therefore the voltage division is constant for any frequency from zero to well above the requirements of the Type 513D. Adjustment of these attenuators is readily made by observation of their square wave response. The self-

contained calibrator in the Type 513D is a suitable square wave source, and thus a check of the attenuators is available by the turn of a switch. A vertical deflection of 2 to 3 cm is recommended. When the variable capacitors in the attenuators are properly adjusted, a square wave will be correctly reproduced by the oscilloscope. If the capacitive divider has a lower attenuation ratio than the resistive divider, a spike appears on the corner of the leading edge. If the capacitive divider has a higher attenuation, the corner of the leading edge is rounded.

The following adjustment procedure is recommended:

1. Lay a sheet of metal on top of the instrument to simulate the presence of the case.
2. Apply a CAL. VOLTAGE of 1.5 volts by setting the VERTICAL INPUT switch in the 1.5 volt CAL. RANGE position and the CAL. VOLTAGE control in the maximum clockwise position. Set the VERT. DEFL. SENS. switch at the 1 to 3 volts per cm position; the VERT. AMPL. ATTEN. control at maximum clockwise position; the sweep time at 200 microseconds per cm. Adjust C1 on the right side of the VERT. DEFL. SENS. switch.
3. Move the VERT. DEFL. SENS. switch to the 3 to 10 volts per cm position and the VERTICAL INPUT switch to 5 volts CAL. RANGE position. Adjust C2 on the left side of the VERT. DEFL. SENS. switch.
4. Move the VERT. DEFL. SENS. switch to the 10 to 30 volts per cm position, and the VERTICAL INPUT switch to the 15 volts CAL. RANGE position. Adjust C3 on the right side of the VERT. DEFL. SENS. switch.
5. Move the VERT. DEFL. SENS. switch to the 30 to 100 volts per cm position, and the VERTICAL INPUT switch to the 50 volts CAL. RANGE position. Adjust C4 on the right side of the VERT. DEFL. SENS. switch.
6. Attach Input Probe to Input 1. Remove the insulated alligator clip and plug the probe into the CAL. OUTPUT connector. Move the VERTICAL INPUT switch to the 5 volts TEST position. Set the sweep time to 600 microseconds per cm. Move the VERT. DEFL. SENS. switch to the 0.3 to 1 volt position. Adjust the probe compensating capacitor (C5).
7. Move the CAL. VOLTAGE control to 1 volt.



Move the VERT. DEFL. SENS. switch to 0.03 to 0.1 volt per cm position. Adjust C6 mounted on the chassis on the right side of the VERT. DEFL. SENS. switch.

8. Move the VERT. DEFL. SENS. switch to the 0.1 to 0.3 volts per cm. position. Set the VERTICAL INPUT switch to the 0.5 volt CAL. RANGE position and the CAL. VOLTAGE control for 0.25 volts. Change the sweep time to 200 microseconds per cm. Adjust C7 on the left side of the VERT. DEFL. SENS. switch.

9. Move the VERTICAL INPUT switch to the 5 volt TEST position, change the sweep time to 600 microseconds per cm, and adjust C8 mounted on the chassis on the left side of the VERT. DEFL. SENS. switch.

10. Move the VERT. DEFL. SENS. switch to the 1 to 3 volts per cm position. Set the VERTICAL INPUT switch at the 50 volts TEST position and the CAL. VOLTAGE control for 20 volts. Adjust C9 mounted on the chassis on the right side of the VERT. DEFL. SENS. switch.

11. Move the VERT. DEFL. SENS. switch to the 3 to 10 volts per cm position and set the CAL. VOLTAGE control for 50 volts. Adjust C10 mounted on the chassis on the right side of the VERT. DEFL. SENS. switch.

12. Move the VERT. DEFL. SENS. switch to the 10 to 30 volts per cm position and adjust C11 located on the left side of the VERT. DEFL. SENS. switch.

13. Move the VERT. DEFL. SENS. switch to the 30 to 100 volts per cm position and adjust C12 located on top of the VERT. DEFL. SENS. switch.

**NOTE** --Greater accuracy in the adjustment of C11 and C12 may be obtained by providing increased signal input and therefore greater vertical deflection. A convenient method is to substitute a 1 megohm variable resistor shunted by a 50  $\mu\mu\text{f}$  capacitor for the probe. With the VERT. DEFL. SENS. switch in the 0.3 to 1 volt per cm position, adjust the variable resistor until the square wave is properly reproduced. Then proceed with the adjustment of C11 and C12, as directed in Steps 12 and 13.

## HIGH FREQUENCY COMPENSATION

The three following sections describe the procedure for high frequency compensation in the Type 513D. Although they are not extremely critical in setting, these adjustments do require considerable care to obtain optimum results.

Since they are very stable, readjustment should not be attempted without first eliminating other possible sources of waveform distortion including defective vacuum tubes and a deficient signal source.

**NOTE** --A suitable square wave generator or pulser unit is necessary in making any high frequency compensation of the Type 513D oscilloscope. The risetime of the square wave generator should not exceed .02 microseconds. The Tektronix Type 105 square wave generator will provide a suitable signal. Before proceeding with the H. F. compensation it is desirable to check the waveform of the generator or pulser unit. This may be checked by making a direct connection to the CRT deflection plates D3 and D4 as outlined in Section II (Operating Instructions).

**CAUTION** --THE LEADS BETWEEN THE TERMINATED CABLE AND THE D3, D4 PLATE CONNECTIONS MUST BE VERY SHORT (2 TO 3 INCHES MAX.) TO PREVENT "RINGING."

In event that the signal under this condition is not large enough to give an image of satisfactory size, it is advisable to remove the three high voltage leads to the post acceleration anodes of the CRT (A3a - A3b - A3c). The anode terminals should then be grounded. Proper safety precautions should be observed in making this test. The disconnected high voltage leads should be supported well away from the frame.

Terminating resistors at BOTH ends of the generator output cable are recommended.

## OUTPUT (DISTRIBUTED) AMPLIFIER

The final vertical amplifier stage of the Type 513D is a 7 section distributed amplifier operated in push-pull. Adjustable series compensating inductors couple the amplifier to the CRT vertical deflection plates. An accurate impedance match between sections of the lines must be maintained to prevent reflections and attendant waveform distortion of the high frequency signal components. The impedance of the line sections are made adjustable by means of 15 grid-line capacitors and 14 plate-line capacitors. They are factory adjusted for optimum transient response, rather than flattest frequency response. This adjustment provides a gradually falling high frequency characteristic



with useful amplification to approximately 30 mc (3DB point--approx. 18 mc). Adjustment is made while observing a 1 mc square wave having a risetime of .02 microseconds or less.

The factory procedure which gives the best transient response consistent with satisfactory frequency response is as follows:

**NOTE**-At all times a CRT image of 2 to 3 cm of deflection should be maintained by proper adjustment of the signal generator amplitude and the VERT. DEFL. SENS. control. The VERT. AMPL. ATTEN. should be at maximum (clockwise). The image should be centered vertically at all times.

1. In the Type 513D (but not in the 513) the DELAY NETWORK must be disconnected before any adjustments are made on the Output Amplifier. This is done as follows:

Disconnect pins 3 and 8 of V7 at the standoff insulator.

Disconnect the wire, running from the lower terminal of the delay line to pins 2 and 7 of V8, at the delay line.

Connect a 100-ohm 1-watt resistor between the free ends of the two wires previously disconnected.

Connect a 300-ohm, 1-watt, precision resistor from pins 2 and 7 of V8 to ground.

The instrument will now operate without the delay network, and the output amplifier may therefore be checked to see if readjustment is necessary. In event that the waveform appears free from major wrinkles and overshoot no further adjustment should be made and the Delay Network should be reconnected and aligned as described below.

2. The plate load resistors should be measured with an accurate bridge. They should be adjusted to 1270 ohms (+or-1%) and matched within +or-1%.

3. Set all the grid line trimmer capacitors (horizontal capacitors on top side of Distributed Amplifier chassis) to approximately 1/3 capacity (set so that slug is about 1/2 of the way into the sleeve).

4. Effectively short out the signal on one side of the push pull amplifier as follows: Disconnect lead between Deflection plate D1 (Yellow) and the coil L14. Insert a 10 meg resistor in this lead. Bypass the Deflection plate side of the

resistor with a .1 mfd capacitor.

5. Apply a 250 KC square wave to INPUT 1 or INPUT 2. Set the SWEEP TIME at .5 microsecond per centimeter. Carefully adjust the plate line trimmer capacitors C46 to C52 (located on the front underside of the amplifier chassis) to give the best possible flat top with minimum wrinkles. These adjustments can be reached with a small insulated screwdriver through the holes in the shield plate. It will be observed that the adjustment of each trimmer controls a bump or wrinkle at a slightly different place along the top of the waveform. The inductance on the load resistor end of the line L9 should be adjusted next. No attempt should be made at this time to adjust the variable inductances on the output end of the plate line (L13). At this point, with proper adjustment, the waveform will tend to have a slight overshoot on the front corner. AN EFFORT SHOULD BE MADE IN MAKING THESE ADJUSTMENTS TO GET THE HEIGHT OF THE SECTION AFFECTED BY THE TRIMMERS TO BE EXACTLY THE SAME AS THE HEIGHT OF THE REST OF THE FLAT TOP. In event that the height is not the same all the trimmers should be slightly adjusted (approx. 1/2 turn) one way or the other and then they should be realigned until the flat top levels are the same.

6. Remove the 10 meg. resistor and .1 mfd capacitor from the Deflection plate D4 and replace the lead going to the inductance (L14), repeat Step 5 with Deflection plate D3 (orange) by-passed. Adjust C68 to C74 and L10 (adjustments on rear of amplifier chassis).

7. Remove the 10 meg resistor and .1 mfd capacitor from Deflection plate D3 and replace the lead to L13.

8. Touch up any of the plate trimmer capacitors as necessary for best waveform. Also slightly readjust L9 and L10 if necessary.

9. Apply a 100 KC square wave and using a sweep time of 4.0 microseconds per cm, observe the squareness of the leading corner of the square wave. The inductances on the output ends of the plate lines (L13 and L14) should be adjusted for best waveform with least overshoot on the leading edge of the wave.

10. With a 1 mc square wave and a sweep time of .1 microsecond per cm, the waveform should be checked and slight adjustments made if necessary to give the best compromise between squareness of the corner and flatness of the level portion is obtained. NOTE--If the above steps are properly made the waveform should look very good at this point--any remaining wrinkles should be so small that they are hardly



visible (Less than 1mm with a 3cm signal deflection).

11. The delay network should be reconnected.

### DELAY NETWORK

The Delay Network is a 40 section, Mderived, artificial transmission line providing a signal delay of .25 microsecond. An accurate impedance match between sections must be maintained to prevent reflections. Each section is adjustable by means of a variable capacitor. The effects of these adjustments are distributed over the first .5 microsecond of the signal.

**CAUTION** --ADJUSTMENT OF THE DELAY NETWORK SHOULD NOT BE ATTEMPTED WITHOUT FIRST VERIFYING NORMAL TRANSIENT RESPONSE OF THE OUTPUT AMPLIFIER, AS EXPLAINED UNDER "OUTPUT (DISTRIBUTED) AMPLIFIER ADJUSTMENT. OTHERWISE THE DELAY NETWORK ADJUSTMENTS MAY BE SET TO COMPENSATE FOR DEFICIENCIES IN THE OUTPUT STAGE.

The recommended (factory) method of adjustment follows:

1. Lay a sheet of metal on the top of the instrument over the output (distributed) amplifier to simulate the presence of the case.
2. Apply a 100 KC square wave to INPUT 1 or INPUT 2. Set the VERT. AMPL. ATTEN. maximum clockwise, and the sweep time at 1 microsecond per cm.
3. Adjust C600 to C639 for the smallest ripple or irregularity on the first .5 microsecond of the square wave. The position of a capacitor along the Delay Network determines which portion of the square wave will be affected by its adjustment. Adding a small additional capacitance to the exposed "hot" terminal of a capacitor (such as by touching it with a screwdriver) will indicate the position of that capacitor's effect, thus simplifying adjustment.
4. Change the sweep time to 4.0 microseconds per cm and observe the squareness of the leading corner. If the corner (first .5 microsecond) is higher in amplitude than the remainder of the square wave, repeat step 3, but setting all the capacitors at higher capacities. If lower, repeat using lower capacity settings. If a square corner cannot thus be obtained, an incorrect Delay Network terminating resistor R44 is indicated. Incorrect resistance may be

caused by a short in V3 or V4. To check this termination, turn off the Type 513D and allow the tubes to cool. Then measure R44 (R601 for SN 1408 and up) with an accurate bridge. If outside the range of 300 ohms  $\pm$  or 1%, replace with a composition resistor selected to be within these limits.

### PREAMPLIFIER H. F. RESPONSE

The Type 513D preamplifier employs both series and shunt compensation to improve the high frequency characteristics. It is factory adjusted for best transient response rather than greatest bandwidth. This is accomplished while observing the response to a 1 mc square wave having a risetime of .02 microseconds or less. The Tektronix Type 105 Square Wave Generator provides a suitable signal.

Set the VERTICAL DEFL. SENS. at either .03 to .1 or .1 to .3 volts per cm position, the VERT. AMPL. ATTEN. fully clockwise, and the sweep time at .2 microsecond per cm. The Signal Generator should be properly terminated and an external "L" pad or "T" pad attenuator used to reduce the signal to a value giving approximately 3 cm of deflection. Adjust L1, L2, L3, and L4 for the squarest corner of the leading edge without overshoot. These adjustments are not very critical; however, it is advisable not to try too much compensation with any one coil but rather to divide the compensation among the four coils.

### DC SHIFT COMPENSATION

At SN 1408 a DC shift compensation network was added to the vertical amplifier. The method of adjusting this network is described in the following paragraph.

Set the AC-DC switch to DC and the VERT. DEFL. SENS. switch to 3 VOLTS/CM. Obtain a free-running slow sweep by adjusting the STABILITY control and position the trace near the bottom graticule line. With the probe, momentarily touch the top terminal of the +15V to 150V PROBE POWER socket and adjust the VERT. AMPL. ATTEN. control so that the positive limit of the trace is just below the top graticule mark. Then repeatedly touch the probe to the terminal and adjust the DC SHIFT COMP control, located on the top of the chassis at the rear, for the least drift of the base line. The time constant of the dc shift is in the neighborhood of 1/2 second.



## DELAY TRIGGER AND GATE

No adjustment is normally required in the Delayed Trigger and Gate generator. However, if tubes are changed, it may be necessary to re-adjust the MULTIVIBRATOR BIAS and the Gate wave form compensation capacitor C503. These adjustments may be made as follows:

The SWEEP TIME should be set to approximately 100 microseconds per cm. A connection should be made between the binding post marked DELAY GATE OUT and INPUT 1 or INPUT 2. The SWEEP STABILITY should be advanced until the sweep is free running. The VERT. DEFL. SENS. should be set to the 10-30 VOLT/CM position. The DELAY TRIG. AND GATE POSITION should be advanced until the delayed gate wave form is displayed in the center of the screen. Notice the form of the leading edge of the gate; it should be square with no overshoot or no tendency to round off. If it is not of the proper shape, it may be squared up by adjusting C503 (located on the terminal board on the underside of the Delayed Trigger chassis). An insulated screwdriver should be used to make this ad-

justment. Adjust the DELAY TRIG AND GATE POSITION control until the gate wave form is in as close as possible to the start of the sweep. The screwdriver adjustment marked MULTI BIAS (R508) should be adjusted, if necessary, to give the best wave form possible, consistent with the ability to position the delayed gate in close to the start of the sweep. It will be noted that every time a change is made in the setting of R508 a re-adjustment will be necessary on the front panel control (DELAY TRIG. AND GATE POSITION).

The Delayed Trigger may now be checked. It is advisable to limit the duty cycle at the highest sweep speeds by triggering the sweep from the TRIGGER RATE GEN., rather than having the sweep free running. The output of the Delayed Trigger should be a positive pulse of the approximately 50 volts peak amplitude when terminated in an external resistor of 100 ohms. The output will be somewhat less, dependent on the duty cycle, if the sweep is free running.



# SECTION 5

## DIAGRAMS

## AND PARTS LIST

Cer.	Ceramic	m	milli or 10
Comp.	Composition	$\Omega$	ohm
EMC	Electrolytic, metal-cased	PBT	Paper, "Bathtub"
f	Farad	PMC	Paper, metal-cased
GMV	Guaranteed mini- mum value	Poly.	Polystyrene
h	Henry	Prec.	Precision
k	Kilohm or 10 ohms	PT	Paper Tubular
M/Cer.	Mica or Ceramic	v	Working volts DC
meg	Megohm or 10 ohms	Var.	Variable
$\mu$	Micro. or 10	w	Watt
$\mu\mu$	Micromicro or 10	WW	Wire-wound

X000 Part first added at this serial number.  
 000X Part removed after this serial number.  
 (Mod. w/) Simple replacement not recommended.  
 Modify to value for later instruments  
 and change other listed parts to match.

### CAPACITORS

Ckt. No.	S/N Range	Description				Part Number
C1	101 up	3-12 $\mu\mu f$	Cer.	Var.	500 v	281-007
C2	101 - up	1.5-7 $\mu\mu f$	Cer.	Var.	500 v	281-005
C3	101 - up	1.5-7 $\mu\mu f$	Cer.	Var.	500 v	281-005
C4	101 - up	1.5-7 $\mu\mu f$	Cer.	Var.	500 v	281-005
C5	101-1074	5-20 $\mu\mu f$	Cer.	Var.	500 v	281-032
	1075 - up	3-12 $\mu\mu f$	Cer.	Var.	500 v	281-008
C6	101 - up	1.5-7 $\mu\mu f$	Cer.	Var.	500 v	281-005
C7	101 - up	3-12 $\mu\mu f$	Cer.	Var.	500 v	281-007
C8	101 - up	3-12 $\mu\mu f$	Cer.	Var.	500 v	281-007
C9	101 - up	3-12 $\mu\mu f$	Cer.	Var.	500 v	281-007
C10	101 - up	3-12 $\mu\mu f$	Cer.	Var.	500 v	281-007





C11	101 - up	3-12 $\mu\mu f$	Cer.	Var.	500 v		281-007
C12	101 - up	3-12 $\mu\mu f$	Cer.	Var.	500 v		281-007
C13	101 - up	27 $\mu\mu f$	Cer.	Fixed	500 v	20%	281-513
C14	101 - up	100 $\mu\mu f$	Mica	Fixed	500 v	20%	283-505
C15	101 - up	330 $\mu\mu f$	Mica	Fixed	500 v	20%	283-518
C16	101 - up	.1 $\mu f$	PT	Fixed	600 v	20%	285-528
C17	101 - up	.001 $\mu f$	Cer.	Fixed	500 v	GMV	283-000
C18	101 - up	20 $\mu f$ (1/2 2x20)	EMC	Fixed	450 v	10%(red dot)	295-038
C19	101 - up	20 $\mu f$ (1/2 2x20)	EMC	Fixed	450 v	-20+50%	
C20	101 - up	20 $\mu f$ (1/2 2x20)	EMC	Fixed	450 v	10%(red dot)	295-038
C21	101 - up	20 $\mu f$ (1/2 2x20)	EMC	Fixed	450 v	-20+50%	
C22	101 - up	.022 $\mu f$	PT	Fixed	400 v	20%	285-515
C23	101 - up	.047 $\mu f$	PT	Fixed	400 v	20%	285-519
C24	101 - up	275 $\mu f$	EMC	Fixed	6 v	-20+50%	290-020
C25	101 - up	275 $\mu f$	EMC	Fixed	6 v	-20+50%	290-020
C26	101 - up	.1 $\mu f$	PT	Fixed	400 v	20%	285-526
C27.1	101 - up	.001 $\mu f$	Cer.	Fixed	500 v	GMV	283-000
C27.2	101 - up	4.7 $\mu\mu f$	Cer.	Fixed	500 v	20%	281-501
C28.1	101 - up	180 $\mu\mu f$	Mica	Fixed	500 v	20%	283-509
C28.2	101 - up	220 $\mu\mu f$	Mica	Fixed	500 v	20%	283-514
C30.1	101 - up	.001 $\mu f$	Cer.	Fixed	500 v	GMV	283-000
C30.2	101 - up	.01 $\mu f$	Cer.	Fixed	500 v	GMV	283-002
C31	101-709X	20 $\mu f$	EMC	Fixed	450 v	-20+50%	290-010
C32	101 - up	20 $\mu f$ (1/2 2x20)	EMC	Fixed	450 v	-20+50% (with C40)	290-110
C33	101-222X	.01 $\mu f$	PT	Fixed	400 v	20%	285-510
C35	101-1770	.1 $\mu f$	PT	Fixed	400 v	20%	285-526
	1771 - up	.005 $\mu f$	Cer.	Fixed	500 v	GMV	283-001
C36	101 - up	.1 $\mu f$	PT	Fixed	400 v	20%	285-526

TYPE 513 - PARTS LIST



CORRECTION FOR  
TYPE 515 COMPOSITE MANUAL

ADD

C37	101-UP	250 PF	MICA	FIXED	500V	20%	283-515
C38	101-UP	.1 $\mu$ F	PT	FIXED	400V	20%	285-526
C39	101-UP	.01 $\mu$ F	PT	FIXED	400V	20%	285-510
C40	101-UP	20 $\mu$ F (1/2 2X20)	EMC	FIXED	450V	-20%+50% (WITH C32)	290-037
C41	101-UP	1000 PF	CER	FIXED	500V	GMV	283-000
C42	101-UP	.01 $\mu$ F	PT	FIXED	400V	20%	285-510
C43.1	101-UP	20 $\mu$ F (1/2 2X20)	EMC	FIXED	450V	-20%+50%	290-010
C43.2	X223-UP	20 $\mu$ F (1/2 2X20)	EMC	FIXED	450V	-20%+50%	290-010
C43.3	X223-UP	20 $\mu$ F (1/2 2X20)	EMC	FIXED	450V	-20%+50% (WITH C52C)	290-010
C44	101-UP	.01 $\mu$ F	PT	FIXED	400V	20%	285-510
C45	101-UP	.01 $\mu$ F	PT	FIXED	400V	20%	285-510
C46-52	101-UP	.5-5 PF	POLY	VAR	500V		281-001
C53	101-1769X	.001 $\mu$ F	MICA	FIXED	500V	5%	283-527
C54-74	101-UP	.5-5 PF	POLY	VAR	500V		281-001
C75	101-1769X	1000 PF	MICA	FIXED	500V	5%	283-527
C76	X1408-UP	.5-5 PF	POLY	VAR	500V		281-001
C77	X1408-UP	.5-5 PF	POLY	VAR	500V		281-001
C88	X1408-UP	2X40 $\mu$ F	EMC	FIXED	250V	-20%+50%	290-040
C90	X1408-UP	2X40 $\mu$ F	EMC	FIXED	250V	-20%+50%	290-040
C101	101-UP	.01 $\mu$ F	PT	FIXED	400V	20%	285-510
C102	101-UP	.01 $\mu$ F	PT	FIXED	400V	20%	285-510
C102.1	101-UP	.1 $\mu$ F	PT	FIXED	400V	20%	285-526
C103	101-UP	20 $\mu$ F (1/2 2X20)	EMC	FIXED	450V	-20%+50% (WITH C512)	290-037
C103.1	101-UP	20 $\mu$ F (1/2 2X20)	EMC	FIXED	450V	-20%+50% (WITH C111)	290-037
C104	101-UP	22 PF	CER	FIXED	500V	10%	281-511

C105	101 - up	220 $\mu\mu\text{f}$	Mica	Fixed	500 v	20%	283-514
C105.1	101 - up	.0015 $\mu\text{f}$	PT	Fixed	400 v	-2 to +20%	285-504
C106	101 - up	.015 $\mu\text{f}$	PT	Fixed	400 v	-2 to +20%	285-512
C107	101 - up	.15 $\mu\text{f}$	PT	Fixed	400 v	-2 to +20%	285-532
C108	101 - up	47 $\mu\mu\text{f}$	Cer.	Fixed	500 v	20%	281-518
C110	101 - up	47 $\mu\mu\text{f}$	Cer.	Fixed	500 v	20%	281-518
C111	101 - up	20 $\mu\text{f}$ (1/2 2x20)	EMC	Fixed	450 v	-20+50% (with C103.2)	290-037
C112	101 - up	7-45 $\mu\mu\text{f}$	Cer.	Var.	500 v		281-012
C113	101 - up	22 $\mu\mu\text{f}$	Cer.	Fixed	500 v	20%	281-510
C114	101 - up	.001 $\mu\text{f}$	Mica	Fixed	500 v	Selected	
C115	101 - up	.01 $\mu\text{f}$	PT	Fixed	400 v	Selected	**295-027
C116	101 - up	.1 $\mu\text{f}$	PT	Fixed	400 v	Selected	
C117	101 - up	1 $\mu\text{f}$	PMC	Fixed	600 v	Selected	
C118	101 - up	.1 $\mu\text{f}$	PT	Fixed	400 v	20%	285-526
C119	101 - up	.01 $\mu\text{f}$	PT	Fixed	600 v	20%	285-511
C120	101 - up	.5 $\mu\text{f}$	PT	Fixed	400 v	20%	285-536
C121	101-1769 1770 - up	47 $\mu\mu\text{f}$ 22 $\mu\mu\text{f}$	Cer. Cer.	Fixed Fixed	500 v 500 v	10% 20%	281-519 281-510
C122	101 - up	7-45 $\mu\mu\text{f}$	Cer.	Var.	500 v		281-012
C123	101 - up	39 $\mu\mu\text{f}$	Cer.	Fixed	500 v	10%	281-516
C124	101 - up	39 $\mu\mu\text{f}$	Cer.	Fixed	500 v	10%	281-516
C125	101-1019	.1 $\mu\text{f}$	EMC	Fixed	400 v		285-515
C125	101-1019X	.1 $\mu\text{f}$	EMC	Fixed	400 v		285-515
C126	101-1019 1020 - up	3x.1 $\mu\text{f}$ .01 $\mu\text{f}$	PBT Cer.	Fixed Fixed	600 v 400 v		285-544 283-002
C127	101-454 455 - up	.001 $\mu\text{f}$ .005 $\mu\text{f}$	Cer. Cer.	Fixed Fixed	500 v 500 v	GMV GMV	283-000 283-001
C128	101-454 455 - up	.001 $\mu\text{f}$ .005 $\mu\text{f}$	Cer. Cer.	Fixed Fixed	500 v 500 v	GMV GMV	283-000 283-001
C129	101 - up	8 $\mu\mu\text{f}$	EMC	Fixed	450 v	-20+50%	290-002



TYPE 513 - PARTS LIST

C130	101 - up	.01 $\mu$ f	PT	Fixed	400 v	20%	285-510
C131	101 - up	8 $\mu$ $\mu$ f	Cer.	Fixed	500 v	10%	281-503
C132	101 - up	8 $\mu$ $\mu$ f	Cer.	Fixed	500 v	10%	281-503
C133	101-1407X	100 $\mu$ $\mu$ f	Cer.	Fixed	500 v	10%	281-530
C134	101 - up	.03 $\mu$ f	PMC	Fixed	2500 v	20%	285-518
C134.1	101 - up	.03 $\mu$ f	PMC	Fixed	2500 v	20%	285-518
C135	101 - up	20 $\mu$ f(1/2 2x20)	EMC	Fixed	450 v	-20+ 50% (with C140)	290-037
C136	101 - up	47 $\mu$ $\mu$ f	Cer.	Fixed	500 v	10%	281-518
C137	101-844	8 $\mu$ $\mu$ f	Cer.	Fixed	500 v	10%	281-503
	845-1407	4.7 $\mu$ $\mu$ f	Cer.	Fixed	500 v	10%	281-501
	1408 - up	12 $\mu$ f	Cer.	Fixed	500 v	10%	281-506
C138	101 - up	6.25 $\mu$ f	EMC	Fixed	300 v	-20+ 50%	290-000
C139	101 - up	.005 $\mu$ f	Cer.	Fixed	500 v	GMV	283-001
C140	101 - up	20 $\mu$ f(1/2 2x20)	EMC	Fixed	450 v	-20+ 50% (with C135)	290-037
C141	101 - up	.005 $\mu$ f	Cer.	Fixed	500 v	20%	283-001
C142	101-1019X	.1 $\mu$ f	EMC	Fixed	400 v		285-515
C144	101 - up	.03 $\mu$ f	PMC	Fixed	2500 v	20%	285-518
C401	101 - up	40 $\mu$ f(2x20)	EMC	Fixed	450 v	-20+ 50%	290-036
C402	101 - up	.01 $\mu$ f	PT	Fixed	600 v	-20+ 50%	285-511
C403	101 - up	40 $\mu$ f(2x20)	EMC	Fixed	450 v	-20+ 50%	209-036
C404	101 - up	.01 $\mu$ f	PT	Fixed	400 v	20%	285-510
C405	101 - up	150 $\mu$ f	EMC	Fixed	150 v	-20+ 50%	290-018
C406	101 - up	200 $\mu$ f5(2x20)	EMC	Fixed	450 v	-20+ 50%	290-037
C407	101 - up	.01 $\mu$ f	PT	Fixed	400 v	20%	285-510
C408	101 - up	.1 $\mu$ f	PT	Fixed	400 v	20%	285-526
C409	101 - up	.01 $\mu$ f	PT	Fixed	400 v	20%	285-510
C410	101 - up	40 $\mu$ f(2x20)	EMC	Fixed	450 v	-20+ 50%	290-036
C411.1	101 - up	40 $\mu$ f(2x20)	EMC	Fixed	450 v	-20+ 50%	290-036

TYPE 513 - PARTS LIST



C411.2	101 - up	40 $\mu$ f(2x20)	EMC	Fixed	450 v	-20+ 50%	290-036
C412.1	101 - up	20 $\mu$ f(1/2 2x20)	EMC	Fixed	450 v	-20+ 50%	290-037
C412.2	101 - up	20 $\mu$ f(1/2 2x20)	EMC	Fixed	450 v	-20+ 50%	
C413	101 - up	.022 $\mu$ f	PT	Fixed	600 v	20%	285-517
C414.1	101 - up	.022 $\mu$ f	PT	Fixed	400 v	20%	285-515
C414.2	101 - up	.022 $\mu$ f	PT	Fixed	400 v	20%	285-515
C415	101 - up	.25 $\mu$ f	PMC	Fixed	2500 v	10%	255-515
C416	101 - up	.01 $\mu$ f	PT	Fixed	400 v	20%	285-510
C417	101-1769	.0047 $\mu$ f	PT	Fixed	6000 v	20%	285-507
	1770 - up	470 $\mu$ $\mu$ f	PT	Fixed	1000 v	20%	285-500
C418	101 - up	.001 $\mu$ f	PT	Fixed	3000 v	10%	285-503
C419.1	101 - up	.015 $\mu$ f	PT	Fixed	3000 v	20%	285-513
C419.2	101 - up	.015 $\mu$ f	PT	Fixed	3000 v	20%	285-513
C420	101 - up	.0068 $\mu$ f	PT	Fixed	5000 v	20%	285-509
C421	101 - up	.0068 $\mu$ f	PT	Fixed	5000 v	20%	285-509
C422	101 - up	.0068 $\mu$ f	PT	Fixed	5000 v	20%	285-509
C423	101 - up	.0068 $\mu$ f	PT	Fixed	5000 v	20%	285-509
C424	101 - up	.0068 $\mu$ f	PT	Fixed	5000 v	20%	285-509
C425	101 - up	.0068 $\mu$ f	PT	Fixed	5000 v	20%	285-509
C501	101 - up	8 $\mu$ $\mu$ f	Cer.	Fixed	500 v	20%	281-503
C502	101 - up	.1 $\mu$ f	PT	Fixed	400 v	20%	285-526
C503	101 - up	1.5-7 $\mu$ $\mu$ f	Cer.	Var.	500 v		281-005
C504	101 - up	47 $\mu$ $\mu$ f	Cer.	Fixed	500 v	20%	281-518
C505	101 - up	47 $\mu$ $\mu$ f	Cer.	Fixed	500 v	20%	281-518
C506	101 - up	5000 $\mu$ $\mu$ f	Cer.	Fixed	500 v	GMV	283-001
C507	101 - up	100 $\mu$ $\mu$ f	Mica	Fixed	500 v	10%	283-505
C508	101 - up	5000 $\mu$ $\mu$ f	Cer.	Fixed	500 v	GMV	283-001
C509	101 - up	5000 $\mu$ $\mu$ f	Cer.	Fixed	500 v	GMV	283-001



TYPE 513 - PARTS LIST

C512	101 - up	20 $\mu$ f	EMC	Fixed	450 v	-20+ 50% (with C103.1)	290-037
C513	101-274	.01 $\mu$ f	PTM	Fixed	400 v	Selected 1%	285-510
	275-1019	.01 $\mu$ f	PTM	Fixed	400 v		285-510
	1020 - up	.001 $\mu$ f	Mica	Fixed	500 v		283-526
C514	101 - up	.1 $\mu$ f(1/3 3x0.1)	PMC	Fixed	400 v	20%	
C515	101 - up	.1 $\mu$ f(1/3 3x0.1)	PMC	Fixed	400 v	20%	285-531
C516.1	101 - up	.1 $\mu$ f(1/3 3x0.1)	PMC	Fixed	400 v	20%	
C516.2	101 - up	.001 $\mu$ f	PT	Fixed	600 v	20%	285-501
C517	101-864	220 $\mu$ $\mu$ f	Mica	Fixed	500 v	10%	283-536
	865 - up	330 $\mu$ $\mu$ f	Mica	Fixed	500 v	10%	283-518
C518	101 - up	.01 $\mu$ f	PT	Fixed	400 v	20%	285-510
C519	101-864	220 $\mu$ $\mu$ f	Mica	Fixed	500 v	10%	283-536
	865 - up	330 $\mu$ $\mu$ f	Mica	Fixed	500 v	10%	283-518
C520	101 - up	20 $\mu$ f(1/2 2x20)	EMC	Fixed	450 v	-20+ 50% (with C43.3)	290-010
C600	X947-1769 1770X	1.5-7 $\mu$ $\mu$ f	Cer.	Var.	500 v		281-005
		3-12 $\mu$ $\mu$ f	Cer.	Var.	500 v		281-007
C601	X1770X	7-45 $\mu$ $\mu$ f	Cer.	Var.	500 v		281-012
C601-C636A	X947-1769X	3-12 $\mu$ $\mu$ f	Cer.	Var.	500 v		281-007
C601-C636B	X947-1769X	12 $\mu$ $\mu$ f	Cer.	Fixed	500 v		281-506
C602	X1770X	7-45 $\mu$ $\mu$ f	Cer.	Var.	500 v		281-012
C603-C638A	X1770X	3-12 $\mu$ $\mu$ f	Cer.	Var.	500 v		281-007
C603B-C638B	X1770X	12 $\mu$ $\mu$ f	Cer.	Fixed	500 v		281-506
C637	X947-1769X	7-45 $\mu$ $\mu$ f	Cer.	Var.	500 v		281-012
C638	X947-1769X	7-45 $\mu$ $\mu$ f	Cer.	Var.	500 v		281-012
C639	X947-1769X	3-12 $\mu$ $\mu$ f	Cer.	Var.	500 v		281-007
	1770 - up	1.5-7 $\mu$ $\mu$ f	Cer.	Var.	500 v		281-005

TYPE 513 — PARTS LIST



### INDUCTORS

L1	101 - up	1.3-2.2 $\mu$ h	Var.				114-003
L2	101 - up	3.3-7.0 $\mu$ h	Var.				114-017
L3	101 - up	.92-1.5 $\mu$ h	Var.				114-028
L4	101 - up	2.4-4.4 $\mu$ h	Var.				114-007
L5	101 - up	Delay Network Inductor(40 section)			Fixed		108-039
L7	101 - up	Dist. Amp. grid inductors					108-037
L8	101 - up	Dist. Amp. grid inductors					108-037
L9	101 - up	2.7-4.8 $\mu$ h	Var.				114-011
L10	101 - up	2.7-4.8 $\mu$ h	Var.				114-011
L11	101 - up	Dist. Amp. plate inductors		Fixed			108-038
L12	101 - up	Dist. amp. plate inductors		Fixed			108-038
L13	101 - up	2.2-4.4 $\mu$ h	Var.		CV222		114-007
L14	101 - up	2.2-4.4 $\mu$ h	Var.		CV222		114-007
L102	101-854	30 $\mu$ h		Fixed			108-037
	855 - up	7.1 $\mu$ h		Fixed			108-020
L104	101-1407X	150 $\mu$ h		Fixed			108-038
	1408 - up	110 $\mu$ h		Fixed			108-002

### RESISTORS

R1	101 - up	47 $\Omega$	1/2 w	Fixed	Comp.	10%	302-470
R3	101 - up	9 meg	1 w	Fixed	Prec.	1%	310-106
R4	101 - up	47 $\Omega$	1/2 w	Fixed	Comp.	10%	302-470
R5	101 - up	700 k	1/2 w	Fixed	Prec.	1%	309-008
R6	101 - up	433 k	1/2 w	Fixed	Prec.	1%	309-001
R7	101 - up	700 k	1/2 w	Fixed	Prec.	1%	309-008
R8	101 - up	433 k	1/2 w	Fixed	Prec.	1%	309-001
R9	101 - up	900 k	1 w	Fixed	Prec.	1%	310-097
R10	101 - up	111 k	1/2 w	Fixed	Prec.	1%	309-046

### TYPE 513 - PARTS LIST



R11	101 - up	966.7 k	1 w	Fixed	Prec.	1%	310-099
R12	101 - up	31.1 k	1/2 w	Fixed	Prec.	1%	309-037
R13	101 - up	990 k	1 w	Fixed	Prec.	1%	310-098
R14	101 - up	10.1 k	1/2 w	Fixed	Prec.	1%	309-034
R15	101 - up	1 meg	1/2 w	Fixed	Prec.	1%	309-014
R16	101 - up	47 $\Omega$	1/2 w	Fixed	Comp.	10%	302-470
R17	101 - up	10 k	2 w	Fixed	Comp.	10%	306-103
R18	101 - up	33 k	1 w	Fixed	Comp.	10%	304-333
R19	101 - up	10 k	2 w	Fixed	Comp.	10%	306-103
R20	101 - up	33 k	1 w	Fixed	Comp.	10%	304-333
R21	101 - up	680 $\Omega$	1/2 w	Fixed	Comp.	+ or -3%	312-507
R22	101 - up	820 $\Omega$	1 w	Fixed	Comp.	-5 to 0%	312-530
R23	101 - up	150 $\Omega$	1/2 w	Fixed	Comp.	5%	301-151
R24	101 - up	270 k	1/2 w	Fixed	Comp.	10%	302-274
R25	101 - up	1 meg	2 w	Var.	Comp.	20%	311-039
R26	101 - up	150 $\Omega$	1/2 w	Fixed	Comp.	5%	301-151
R27	101 - up	27 $\Omega$	1/2 w	Fixed	Comp.	10%	302-270
R28	101 - up	1 meg	1/2 w	Fixed	Comp.	10%	302-105
R29	101 - up	100 $\Omega$	1/2 w	Fixed	Comp.	10%	302-101
R30	101 - up	220 $\Omega$	1/2 w	Fixed	Comp.	10%	302-221
R31	101 - up	27 $\Omega$	1/2 w	Fixed	Comp.	10%	302-270
R32	101 - up	27 $\Omega$	1/2 w	Fixed	Comp.	10%	302-270
R33	101 - up	1 meg	1/2 w	Fixed	Comp.	10%	302-105
R34	101 - up	1 meg	1/2 s	Fixed	Prec.	1%	309-014
R35.1	101 - up	47 $\Omega$	1/2 w	Fixed	Comp.	10%	302-470
R35.2	101 - up	47 $\Omega$	1/2 w	Fixed	Comp.	10%	302-470
R36	101 - up	27 $\Omega$	1/2 w	Fixed	Comp.	10%	302-270
R37	101 - up	100 $\Omega$	1/2 w	Fixed	Comp.	10%	302-101

TYPE 513 - PARTS LIST





R38	101-222 223 - up	2.2 k 1 k	1 w 1 w	Fixed Fixed	Comp. Comp.	10% 10%	304-222 304-102
R39	101 - up	47 $\Omega$	1/2 w	Fixed	Comp.	10%	302-470
R40	101 - up	1 meg	1/2 w	Fixed	Comp.	10%	302-105
R41	101 - up	150 $\Omega$	1/2 w	Fixed	Comp.	10%	302-151
R42	101-222 223 - up	1 k 1.8 k	1/2 w 1/2 w	Fixed Fixed	Comp. Comp.	5% 5%	301-102 301-182
R43	101 - up	6.8 k	1 w	Fixed	Comp.	10%	304-682
R44	101-946X	300 $\Omega$	1/2 w	Fixed	Prec.	1%	309-076
R45	101-694X	470 $\Omega$	1/2 w	Fixed	Comp.	10%	302-471
R45.1	X695 - up	343 $\Omega$	1/2 w	Fixed	Prec.	1%	309-078
R46	101 - up	27 $\Omega$	1/2 w	Fixed	Comp.	10%	302-270
R47	101 - up	27 $\Omega$	1/2 w	Fixed	Comp.	10%	302-270
R49	101 - up	1 k	2 w	Var.	Comp.	20%	311-006
R50	101 - up	10 k	2 w	Var.	WW	20%	311-015
R51	101 - up	10 k	2 w	Fixed	Comp.	10%	306-103
R52	101-694 695 - up	18 k 15 k	2 w 2 w	Fixed Fixed	Comp. Comp.	Selected Selected	305-183 312-545
R53	101-694 695 - up	22 k 12 k	2 w 2 w	Fixed Fixed	Comp. Comp.	Selected Selected	305-223 312-545
R54.1	101 - up	27 $\Omega$	1/2 w	Fixed	Comp.	10%	302-270
R54.2	101 - up	27 $\Omega$	1/2 w	Fixed	Comp.	10%	302-270
R55	101 - up	390 $\Omega$	1 w	Fixed	Comp.	0 to -5%	312-529
R56	101-1770 1771 - up	1.11 meg 22 meg	1/2 w 1/2 w	Fixed Fixed	Prec. Comp.	1% 10%	309-015 302-226
R57	101-1770 1771 - up	5.6 k 120 k	1/2 w 1/2 w	Fixed Fixed	Comp. Comp.	10% 10%	302-562 302-124
R58	101-1770 1771 - up	100 k 500 k	2 w 2 w	Var. Var.	Comp. Comp.	20% 20%	311-026 311-036
R59	101-1770 1771 - up	10 k 100 k	2 w 2 w	Var. Var.	WW Comp.	10% 10%	311-015 311-026

TYPE 513 - PARTS LIST



R60	X164-363	22 k	1/2 w	Fixed	Comp.	10%	302-223
	364-1770	18 k	1/2 w	Fixed	Comp.	10%	302-183
	1771 - up	3.3 k	1/2 w	Fixed	Comp.	10%	302-332
R61	101-1770	100 k	1/2 w	Fixed	Comp.	10%	302-104
	1771 - up	120 k	1/2 w	Fixed	Comp.	10%	302-124
R62	101-1769	47 $\Omega$	1/2 w	Fixed	Comp.	10%	302-470
	1770 - up	10 $\Omega$	1/2 w	Fixed	Comp.	10%	302-100
R63	101 - up	47 $\Omega$	1/2 w	Fixed	Comp.	10%	302-470
R64	101 - up	47 $\Omega$	1/2 w	Fixed	Comp.	10%	302-470
R65	101-1769	47 $\Omega$	1/2 w	Fixed	Comp.	10%	302-470
	1770 - up	10 $\Omega$	1/2 w	Fixed	Comp.	10%	302-100
R66	101 - up	47 $\Omega$	1/2 w	Fixed	Comp.	10%	302-470
R67	101 - up	47 $\Omega$	1/2 w	Fixed	Comp.	10%	302-470
R68	X164 - up	390 $\Omega$	1 w	Fixed	Comp.	0 to +10%	312-528
R69	X164 - up	390 $\Omega$	1 w	Fixed	Comp.	0 to +10%	312-528
R70	101-222	39 $\Omega$	1/2 w	Fixed	Comp.	10%	302-330
	223 - up	47 $\Omega$	1/2 w	Fixed	Comp.	10%	302-470
R71	101 - up	8.2 k	2 w	Fixed	Comp.	10%	306-822
R72	101-222	47 $\Omega$	1/2 w	Fixed	Comp.	10%	302-470
	223 - up	10 $\Omega$	1/2 w	Fixed	Comp.	10%	302-100
R73	101 - up	47 $\Omega$	1/2 w	Fixed	Comp.	10%	302-470
R74	101 - up	47 $\Omega$	1/2 w	Fixed	Comp.	10%	302-470
R75	101-222	47 $\Omega$	1/2 w	Fixed	Comp.	10%	302-470
	223 - up	10 $\Omega$	1/2 w	Fixed	Comp.	10%	302-100
R76	101 - up	47 $\Omega$	1/2 w	Fixed	Comp.	10%	302-470
R77	101 - up	47 $\Omega$	1/2 w	Fixed	Comp.	10%	302-470
R78	101 - up	1 meg	2 w	Var.	Comp.	20%	311-039
R79	101 - up	470 k	1/2 w	Fixed	Comp.	10%	302-474
R80	101 - up	100 $\Omega$	1/2 w	Fixed	Comp.	10%	302-101
R80.1	X1770 - up	470 k	1/2 w	Fixed	Comp.	10%	302-474
R81	101 - up	100 k	1/2 w	Fixed	Prec.	1%	309-045
R82	101-799	48 k	1/2 w	Fixed	Prec.	1%	use 309-039
	800 - up	50 k	1/2 w	Fixed	Prec.	1%	309-039

TYPE 513 - PARTS LIST



R83	101 - up	47 $\Omega$	1/2 w	Fixed	Comp.	10%	302-470
R84	101 - up	670 $\Omega$	1/2 w	Fixed	Prec.	1%	309-082
R85	101 - up	670 $\Omega$	1/2 w	Fixed	Prec.	1%	309-082
R86	101 - up	670 $\Omega$	1/2 w	Fixed	Prec.	1%	309-082
R87	101 - up	670 $\Omega$	1/2 w	Fixed	Prec.	1%	309-082
R88	101-1410 1411 - up	1 k 1420 $\Omega$	25 w 25 w	Fixed Fixed	WW WW	See Note	use 308-038 312-550
R88.1	X1411 - up	12 k	1 w	Fixed	Comp.	See Note	
R89	101-1410 1411 - up	Selected 500 k	2 w	Var.	Comp.	See Note 20%	311-034
R90	101-1410 1411 - up	1 k 1420 $\Omega$	25 w 25 w	Fixed Fixed	WW WW	See Note	use 308-038 312-550
R90.1	X1411 - up	12 k	1 w	Fixed	Comp.	See Note	
R91	101-1410X	Selected				See Note	
R92	101 - up	47 $\Omega$	1/2 w	Fixed	Comp.	10%	302-470
R92.1	101 - up	47 $\Omega$	1/2 w	Fixed	Comp.	10%	302-470
R92.2	101 - up	47 $\Omega$	1/2 w	Fixed	Comp.	10%	302-470
R92.3	101 - up	47 $\Omega$	1/2 w	Fixed	Comp.	10%	302-470
R92.4	101 - up	47 $\Omega$	1/2 w	Fixed	Comp.	10%	302-470
R92.5	101 - up	47 $\Omega$	1/2 w	Fixed	Comp.	10%	302-470
R92.6	101 - up	47 $\Omega$	1/2 w	Fixed	Comp.	10%	302-470
R93	101-1769X	100 k	1/2 w	Fixed	Comp.	10%	302-104
R94	101 - up	2.2 k	1/2 w	Fixed	Comp.	10%	302-222
R95	101 - up	47 $\Omega$	1/2 w	Fixed	Comp.	10%	302-470
R95.1	101 - up	47 $\Omega$	1/2 w	Fixed	Comp.	10%	302-470
R95.2	101 - up	47 $\Omega$	1/2 w	Fixed	Comp.	10%	302-470
R95.3	101 - up	47 $\Omega$	1/2 w	Fixed	Comp.	10%	302-470
R95.4	101 - up	47 $\Omega$	1/2 w	Fixed	Comp.	10%	302-470
R95.5	101 - up	47 $\Omega$	1/2 w	Fixed	Comp.	10%	302-470



### TYPE 513 -- PARTS LIST

R95.6	101 - up	47 $\Omega$	1/2 w	Fixed	Comp.	10%	302-470
R96	X131 - up	1 k	25 w	Fixed	WW	5%	308-037
R97	101-1769X	100 k	1/2 w	Fixed	Comp.	10%	302-104
R98	101 - up	2.2 k	1/2 w	Fixed	Comp.	10%	302-222
R101	101 - up	22 meg	1/2 w	Fixed	Comp.	10%	302-226
R102	101 - up	1 meg	1/2 w	Fixed	Comp.	10%	302-105
R103	101 - up	47 $\Omega$	1/2 w	Fixed	Comp.	10%	302-470
R104	101 - up	470 k	1/2 w	Fixed	Comp.	10%	302-474
R105	101 - up	330 $\Omega$	1/2 w	Fixed	Comp.	10%	302-331
R106	101-854	1.5 k	1/2 w	Fixed	Comp.	10%	302-152
	855 - up	120 $\Omega$	1/2 w	Fixed	Comp.	10%	302-121
R107	101 - up	4.7 k	2 w	Fixed	Comp.	10%	306-472
R108	101-854	1.5 k	1/2 w	Fixed	Comp.	10%	302-152
	855 - up	560 $\Omega$	1/2 w	Fixed	Comp.	10%	302-561
R109	101 - up	47 $\Omega$	1/2 w	Fixed	Comp.	10%	302-470
R110	101 - up	1 meg	1/2 w	Fixed	Comp.	10%	302-105
R111	101-127	8.2 k	2 w	Fixed	Comp.	10%	306-822
	128 - up	10 k	2 w	Fixed	Comp.	10%	306-103
R111.1	X1020 - up	47 $\Omega$	1/2 w	Fixed	Comp.	10%	302-470
R112	101 - up	1 k	1 w	Fixed	Comp.	10%	304-102
R113	101 - up	500 k	2 w	Var.	Comp.	Special (Ganged with R142)	311-038
R114	101 - up	1/5 meg	1/2 w	Fixed	Comp.	10%	302-155
R115	101 - up	4.7 k	2 w	Fixed	Comp.	10%	306-472
R115.1	101 - up	4.7 k	2 w	Fixed	Comp.	10%	306-472
R116	101 - up	47 $\Omega$	1/2 w	Fixed	Comp.	10%	302-470
R116.1	X1075 - up	3.9 meg	1/2 w	Fixed	Comp.	10%	302-395
R117	101 - up	220 k	1/2 w	Fixed	Comp.	10%	302-224
R118	101 - up	100 k	1/2 w	Fixed	Comp.	10%	302-104
R119	101 - up	100 k	2 w	Var.	Comp.	20%	311-026

TYPE 513 - PARTS LIST



R120	101 - up	220 k	1 w	Fixed	Comp.	10%	304-224
R121	101 - up	220 k	1/2 w	Fixed	Comp.	10%	302-224
R121.1	101 - up	200 k	1/2 w	Fixed	Prec.	1%	309-051
R122	101 - up	2x220 k	2 w	Var.	Comp.	20%	312-100
R123	101 - up	2.2 k	2 w	Fixed	Comp.	10%	306-222
R123.1	101 - up	2.7 k	2 w	Fixed	Comp.	10%	306-272
R124	101 - up	47 $\Omega$	1/2 w	Fixed	Comp.	10%	302-470
R125	101 - up	10 k	2 w	Fixed	Comp.	10%	306-103
R126	101 - up	10 k	2 w	Fixed	Comp.	10%	306-103
R127	101 - up	15 k	1 w	Fixed	Comp.	10%	304-153
R128	101 - up	120 k	1/2 w	Fixed	Comp.	10%	302-124
R129	101-474	100 k	1/2 w	Fixed	Comp.	10%	302-124
	475-624	120 k	1/2 w	Fixed	Comp.	10%	302-124
	625 - up	100 k	1/2 w	Fixed	Comp.	10%	302-104
R130	101 - up	47 $\Omega$	1/2 w	Fixed	Comp.	10%	302-470
R131	101 - up	15 k	2 w	Fixed	Comp.	10%	306-153
R132	101-1769	4.7 k	1/2 w	Fixed	Comp.	10%	302-472
	1770 - up	1 k	1/2 w	Fixed	Comp.	10%	302-102
R133	101 - up	22 meg	1/2 w	Fixed	Comp.	10%	302-226
R133.1	101 - up	10 meg	1/2 w	Fixed	Comp.	10%	302-106
R134	101 - up	680 k	1 w	Fixed	Comp.	10%	304-684
R135	101 - up	270 k	1/2 w	Fixed	Comp.	10%	302-274
R136	101 - up	500 k	2 w	Var.	Comp.	10%	311-034
R137	101 - up	470 k	1/2 w	Fixed	Comp.	10%	302-474
R138	101-1019	18 meg	1/2 w	Fixed	Comp.	10%	302-186
	1020 - up	22 meg	1/2 w	Fixed	Comp.	10%	302-226
R138.1	101-1019	15 meg	1/2 w	Fixed	Comp.	10%	302-156
	1020 - up	10 meg	1/2 w	Fixed	Comp.	10%	302-106
R139	101 - up	200 k	2 w	Fixed	Prec.	1%	309-110
R140	101 - up	22 meg	1/2 w	Fixed	Comp.	10%	302-226



TYPE 513 - PARTS LIST

R140.1	101 - up	10 meg	1/2 w	Fixed	Comp.	10%	302-106
R141	101 - up	100 $\Omega$	1/2 w	Fixed	Comp.	10%	302-101
R142	101 - up	100 k	2 w	Var.	Comp.	20%	311-038
R143	101 - up	8.2 k	2 w	Fixed	Comp.	10% (with R113)	306-822
R144	101 - up	5 k	2 w	Var.	Comp.	20%	311-011
R145	101 - up	820 k	1/2 w	Fixed	Comp.	10%	302-824
R146	101 - up	100 k	2 w	Var.	Comp.	20%	311-026
R147	101-1019 1020 - up	82 k 470 k	1/2 w 1/2 w	Fixed Fixed	Comp. Comp.	10% 10%	302-823 302-474
R148	101 - up	2.7 k	1/2 w	Fixed	Comp.	10%	302-272
R149	101 - up	2.7 k	1/2 w	Fixed	Comp.	10%	302-272
R150	101 - up	6.8 k	1/2 w	Fixed	Comp.	10%	302-682
R151	101-1896 1897 - up	12 k 15 k	2 w 2 w	Fixed Fixed	Comp. Comp.	10% 10%	306-123 306-153
R152	101-1896 1897 - up	12 k 15 k	2 w 2 w	Fixed Fixed	Comp. Comp.	10% 10%	306-123 306-153
R153	101 - up	100 k	1/2 w	Fixed	Prec.	1%	309-045
R154	101 - up	82 k	1/2	Fixed	Prec.	1%	309-043
R155	101 - up	82 k	1/2 w	Fixed	Prec.	1%	309-043
R156	101 - up	100 k	1/2 w	Fixed	Prec.	1%	309-045
R157	101-1769 1770 - up	150 k 66 k	2 w 4 w	Fixed Fixed	Comp. Comp.	10% 10%	306-154 306-333
R158	101-1769 1770 - up	150 k 66 k	2 w 4 w	Fixed Fixed	Comp. Comp.	10% 10%	306-154 306-333
R159	101 - up	25 k	25 w	Fixed	WW	10%	312-551
R160	101 - up	47 $\Omega$	1/2 w	Fixed	Comp.	10%	302-470
R161	101 - up	47 $\Omega$	1/2 w	Fixed	Comp.	10%	302-470
R162	101 - up	25 k	25 w	Fixed	WW	10%	312-551
R163	101 - up	330 $\Omega$	1 w	Fixed	Comp.	10%	304-331
R164	101 - up	82 $\Omega$	1/2 w	Fixed	Comp.	10%	302-820

TYPE 513 - PARTS LIST



R165	101 - up	82 Ω	1/2 w	Fixed	Comp.	10%	302-820
R166	101-454 455 - up	220 k 470 k	1 w 1 w	Fixed Fixed	Comp. Comp.	10% 10%	304-224 304-474
R167	101-454 455 - up	220 k 470 k	1 w 1 w	Fixed Fixed	Comp. Comp.	10% 10%	304-224 304-474
R168	101 - up	10 k	1 w	Fixed	Comp.	10%	304-103
R169	101-454 455 - up	12 k 10 k	1/2 w 1/2 w	Fixed Fixed	Comp. Comp.	10% 10%	302-123 302-103
R170	101-454 455 - up	10 k 20 k	2 w 2 w	Var. Var.	Comp. Comp.	20% 20%	311-016 311-018
R171	101-454 455 - up	10 k 20 k	2 w 2 w	Var. Var.	Comp. Comp.	20% 20%	311-016 311-018
R172	101-454 455 - up	12 k 10 k	1/2 w 1/2 w	Fixed Fixed	Comp. Comp.	10% 10%	302-123 302-103
R173	101 - up	1 k	1/2 w	Fixed	Comp.	10%	302-102
R174	101 - up	1 k	1/2 w	Fixed	Comp.	10%	302-102
R175	101 - up	47 k	1/2 w	Fixed	Comp.	10%	302-473
R176	101 - up	47 k	1/2 w	Fixed	Comp.	10%	302-473
R177	101-454 455 - up	120 k 270 k	1/2 w 1/2 w	Fixed Fixed	Comp. Comp.	10% 10%	302-124 302-274
R178	101-454 455 - up	120 k 270 k	1/2 w 1/2 w	Fixed Fixed	Comp. Comp.	10% 10%	302-124 302-274
R179	101-222 223-454 455 - up	560 k 500 k 68 k	1/2 w 1/2 w 1/2 w	Fixed Fixed Fixed	Comp. Prec. Comp.	5% 1% 10%	301-564 309-003 302-683
R180	101-454 455 - up	3.3 meg 1 meg	1/2 w 1/2 w	Fixed Fixed	Comp. Comp.	10% 10%	302-335 302-105
R181	101 - up	470 k	1/2 w	Fixed	Comp.	10%	302-474
R182	101 - up	470 k	1/2 w	Fixed	Comp.	10%	302-474
R183	101 - up	47 Ω	1/2 w	Fixed	Comp.	10%	302-470
R183.1	101 - up	10 k	1 w	Fixed	Comp.	10%	304-103
R184	101 - up	100 k	1/2 w	Fixed	Prec.	1%	309-045
R185	101-1019 1020 - up	100 k 95 k	1/2 w 1/2 w	Fixed Fixed	Prec. Prec.	1% 1%	309-045 309-044

TYPE 513 - PARTS LIST



R186	101 - up	2.7 k	2 w	Fixed	Comp.	10%	306-272
R187	101-1407	4.7 k	1 w	Fixed	Comp.	10%	304-472
	1408 - up	1.5 k	1 w	Fixed	Comp.	10%	304-152
R187.1	X1408 - up	2.7 k	2 w	Fixed	Comp.	10%	306-272
R188	101 - up	47 k	2 w	Fixed	Comp.	10%	306-473
R190	101 up	150 k	1/2 w	Fixed	Prec.	1%	309-049
R191	101 - up	220 k	1/2 w	Fixed	Prec.	1%	309-052
R192	101 - up	220 k	1/2 w	Fixed	Comp.	10%	302-224
R193	101 - up	150 k	1/2 w	Fixed	Comp.	10%	302-154
R194	101 - up	100 k	2 w	Var.	Comp.	20%	311-026
R195	101-1407	4.7 k	2 w	Fixed	Comp.	10%	306-472
	1408 - up	6.8 k	2 w	Fixed	Comp.	10%	306-682
R196	101-1407	2.2 k	1 w	Fixed	Comp.	10%	304-222
	1408 - up	3.9 k	1 w	Fixed	Comp.	10%	304-392
R197	101-1407	15 k	2 w	Fixed	Comp.	10%	306-153
	1408 - up- up	6.8 k	2 w	Fixed	Comp.	10%	306-682
	1408 - up	6.8 k	2 w	Fixed	Comp.	10%	306-682
R197.1	X845-1407	15 k	2 w	Fixed	Comp.	10%	306-153
	1408 - up	6.8 k	2 w	Fixed	Comp.	10%	306-682
R198	101-1019	18 k	2 w	Fixed	Comp.	10%	306-183
	1020-1407	39 k	2 w	Fixed	Comp.	10%	306-393
	1408 - up	33 k	2 w	Fixed	Comp.	10%	306-333
R198.1	X1020-1407	39 k	2 w	Fixed	Comp.	10%	306-393
	1408 - up	33 k	2 w	Fixed	Comp.	10%	306-333
R199	101 - up	22 k	1/2 w	Fixed	Comp.	10%	302-223
R199.1	X1408 - up	330 k	1/2 w	Fixed	Comp.	10%	302-334
R200	101 - up	47 k	1 w	Fixed	Comp.	10%	304-473
R201	101 - up	470 Ω	1/2 w	Fixed	Comp.	10%	302-471
R202	101 - up	22 k	2 w	Fixed	Comp.	10%	306-223
R203	101 - up	10 k	1 w	Fixed	Comp.	10%	304-103
R204	101 - up	4.7 k	1 w	Fixed	Comp.	10%	304-472
R205	101 - up	680 k	1/2 w	Fixed	Comp.	10%	302-684

TYPE 513 - PARTS LIST





R 206	101 - up	100 k	1/2 w	Var.	WW (Combined with SW104)	20%	311-027
R 207	101 - up	8.2 k	1/2 w	Fixed	Comp.	10%	302-822
R 208	101 - up	500 k	2 w	Var.	Comp.	20%	311-034
R 209	101 - up	4.7 meg	2 w	Fixed	Comp.	10%	306-475
R 210	101 - up	2 meg	2 w	Var.	Comp.	20%	311-042
R 211	101-1769 1770 - up	1.5 meg 1 meg	2 w 2 w	Fixed Fixed	Comp. Comp.	10% 10%	306-155 306-105
R 212	101 - up	2 meg	2 w	Var.	Comp.	20%	311-042
R 213	101 - up	1.5 meg	1/2 w	Fixed	Comp.	10%	302-155
R 214	101 - up	100 k	1 w	Fixed	Comp.	10%	304-104
R 215	101-1019 1020 - up	1 meg 1.5 meg	1 w 1 w	Fixed Fixed	Comp. Comp.	10% 10%	304-105 304-155
R 216	101 - up	470 k	1/2 w	Fixed	Comp.	10%	302-474
R 217	101 - up	100 k	1/2 w	Fixed	Comp.	10%	302-104
R 220	X1861 - up	1 meg	1/2 w	Fixed	Comp.	10%	302-105
R 226	X1770 - up	500 k	2 w	Var.	Comp.	20%	311-034
R 227	X1888 - up	10 meg	1/2 w	Fixed	Comp.	10%	302-106
R 401.1	101 - up	470 k	1 w	Fixed	Comp.	10%	304-474
R 401.2	101 - up	470 k	1/2 w	Fixed	Comp.	10%	302-474
R 402	101 - up	220 k	2 w	Fixed	Comp.	10%	306-224
R 403	101 - up	1.75 meg	1 w	Fixed	Prec.	1%	301-101
R 404	101 - up	47 k	1/2 w	Fixed	Comp.	10%	302-473
R 405	101 - up	666.6 k	1/2 w	Fixed	Prec.	1%	309-007
R 406	101 - up	2 k	20 w	Fixed	WW	5%	308-031
R 407.1	101 - up	470 k	1/2 w	Fixed	Comp.	10%	302-474
R 407.2	101 - up	47 Ω	1/2 w	Fixed	Comp.	10%	302-470
R 408	101 - up	82 k	1 w	Fixed	Comp.	10%	304-823
R 409	101 - up	22 k	1/2 w	Fixed	Comp.	10%	302-223
R 410	101 - up	470 k	1/2 w	Fixed	Comp.	10%	302-474



**TYPE 513 - PARTS LIST**

R411	101 - up	1.5 meg	1/2 w	Fixed	Prec.	1%	309-017
R412	101-222	750 k	1/2 w	Fixed	Prec.	1%	309-010
	223-2023	720 k	1/2 w	Fixed	Prec.	1%	309-009
	2024 - up	750 k	1/2 w	Fixed	Prec.	1%	309-010
R413.1	101 - up	1.5 k	25 w	Fixed	WW	5%	308-040
R413.2	101 - up	1.5 k	25 w	Fixed	WW	5%	308-040
R414.1	101 - up	1 k	1/2 w	Fixed	Comp.	10%	302-102
R414.2	101 - up	1 k	1/2 w	Fixed	Comp.	10%	302-102
R415	101 - up	470 k	1/2 w	Fixed	Comp.	10%	302-474
R416	101 - up	56 k	1 w	Fixed	Comp.	10%	304-563
R417	101 - up	2.2 meg	1/2 w	Fixed	Comp.	10%	302-225
R418	101 - up	22 k	1/2 w	Fixed	Comp.	10%	302-223
R419	101 - up	2.2 meg	1/2 w	Fixed	Comp.	10%	302-225
R420	101 - up	68 k	1/2 w	Fixed	Comp.	10%	302-683
R421	101 - up	560 k	1/2 w	Fixed	Comp.	5%	301-564
R422	101 - up	220 k	1/2 w	Fixed	Comp.	10%	302-224
R423	101 - up	1.5 meg	1/2 w	Fixed	Comp.	10%	302-155
R424	101 - up	470 k	1/2 w	Fixed	Comp.	10%	302-474
R425	101 - up	100 k	2 w	Var.	Comp.	20%	311-026
R426	101 - up	270 k	1/2 w	Fixed	Comp.	10%	302-274
R427	101 - up	270 k	1/2 w	Fixed	Comp.	10%	302-274
R428	101-222	3 k	25 w	Fixed	WW	5%	308-042
	223-1612	2.4 k	25 w	Fixed	WW	5%	308-041
	1613 - up	3.8 k	25 w	Fixed	WW	5%	308-044
R429	101-1612	470 $\Omega$	1 w	Fixed	Comp.	10%	304-471
	1613 - up	390 $\Omega$	1 w	Fixed	Comp.	10%	304-391
R430	101-1019	470 $\Omega$	1 w	Fixed	Comp.	10%	304-471
	1020-1612	330 $\Omega$	1 w	Fixed	Comp.	10%	304-331
	1613 - up	390 $\Omega$	1 w	Fixed	Comp.	10%	304-391
R431	101 - up	50 $\Omega$	2 w	Var.	WW	5%	311-002
R432	101 - up	47 $\Omega$	1/2 w	Fixed	Comp.	10%	302-470
R433	101 - up	220 k	1/2 w	Fixed	Comp.	10%	302-224

TYPE 513 - PARTS LIST



R434	101 - up	150 k	1/2 w	Fixed	Comp.	10%	302-154
R435	101-157 158 - up	68 k 470 k	1/2 w 1/2 w	Fixed Fixed	Comp. Comp.	10% 10%	302-683 302-474
R436	101 - up	4.7 k	2 w	Fixed	Comp.	10%	306-472
R437	101 - up	3.3 k	1/2 w	Fixed	Comp.	10%	302-332
R438	101 -up	120 k	1/2 w	Fixed	Comp.	10%	302-124
R439.1	101 - up	470 k	1/2 w	Fixed	Comp.	10%	302-474
R439.2	101 - up	150 Ω	1/2 w	Fixed	Comp.	10%	302-151
R440	101 - up	2.7 meg	1 w	Fixed	Comp.	10%	304-275
R441	101 - up	2 meg	2 w	Var.	Comp.	20%	311-042
R442	101 - up	30 meg	2 w	Fixed	Comp.	10%	314-003
R443	101 - up	30 meg	2 w	Fixed	Comp.	10%	314-003
R444	101 - up	30 meg	2 w	Fixed	Comp.	10%	314-003
R445	101 - up	4.7 meg	1/2 w	Fixed	Comp.	10%	302-475
R446	101 - up	10 meg	1/2 w	Fixed	Comp.	10%	302-106
R447	101 - up	10 meg	1/2 w	Fixed	Comp.	10%	302-106
R448	101-1019 1020 - up	2.2 meg 2.7 meg	1/2 w 1/2 w	Fixed Fixed	Comp. Comp.	10% 10%	302-225 302-275
R449.1	101-1019 1020 - up	110 k 100 k	1 w 1 w	Fixed Fixed	Comp. Comp.	5% 10%	303-114 304-104
R450	101 - up	30 meg	2 w	Fixed	Comp.	10%	312-540
R451.1	101 - up	6.8 meg	1/2 w	Fixed	Comp.	10%	
R452	X1613 - up	3.8 k	25 w	Fixed	WW	5%	308-044
R455	X1546 - up	15 k	10 w	Fixed	WW	5%	308-024
R501	101 - up	250 k	2 w	Var.	Comp. (combined with SW501)	10%	311-033
R502	101 - up	33 k	1/2 w	Fixed	Comp.	10%	302-333
R503	101 - up	120 k	1/2 w	Fixed	Comp.	10%	302-124
R504	101 - up	8.2 k	2 w	Fixed	Comp.	10%	306-822
R505	101 - up	8.2 k	2 w	Fixed	Comp.	10%	306-822



#### TYPE 513 - PARTS LIST

R506	101 - up	150 k	1/2 w	Fixed	Comp.	10%	302-154
R507	101 - up	68 k	1/2 w	Fixed	Comp.	10%	302-683
R508	101 - up	100 k	2 w	Var.	Comp.	20%	311-026
R509	101 - up	680 Ω	1 w	Fixed	Comp.	10%	304-681
R510	101 - up	470 k	1/2 w	Fixed	Comp.	10%	302-474
R511	101 - up	470 k	1/2 w	Fixed	Comp.	10%	302-474
R512	101 - up	10 k	1 w	Fixed	Comp.	10%	304-103
R513	101 - up	47 k	1/2 w	Fixed	Comp.	10%	302-473
R514	101 - up	470 k	1/2 w	Fixed	Comp.	10%	302-474
R515	101 - up	470 k	1/2 w	Fixed	Comp.	10%	302-474
R516	101 - up	22 k	1/2 w	Fixed	Comp.	10%	302-223
R517	101 - up	150 k	1/2 w	Fixed	Comp.	10%	302-154
R518	101 - up	8.2 k	2 w	Fixed	Comp.	10%	306-822
R519	101 - up	8.2 k	2 w	Fixed	Comp.	10%	306-822
R520	101 - up	470 k	1/2 w	Fixed	Comp.	10%	302-474
R521	101-2010 2011 - up	33 k 47 k	1/2 w 1/2 w	Fixed Fixed	Comp. Comp.	10% 10%	302-333 302-473
R522	101 - up	150 k	1/2 w	Fixed	Comp.	10%	302-154
R523	101 - up	4.7 k	1 w	Fixed	Comp.	10%	304-472
R528	101 - up	470 Ω	1 w	Fixed	Comp.	10%	304-471
R529	101-274 275-1019 1020 - up	68 k 82 k 400 k	1 w 1 w 1 w	Fixed Fixed Fixed	Prec. Comp. Prec.	1%  1%	310-054 use 304-823 310-094
R530	101-274 275-1019 1020 - up	150 k 180 k 1 meg	1 w 1 w 1 w	Fixed Fixed Fixed	Comp. Comp. Prec.	10% 10% 1%	use 304-154 use 304-184 310-100
R531	101-274 275-1019 1020 - up	270 k 330 k 2 meg	1/2 w 1/2 w 1 w	Fixed Fixed Fixed	Comp. Prec. Prec.	10% 1% 1%	use 302-274 309-101 310-102
R532	101-274 275-1019 1020 - up	470 k 680 k 4 meg	1/2 w 1/2 w 1 w	Fixed Fixed Fixed	Comp. Comp. Prec.	10% 10% 1%	use 302-474 use 302-684 310-103

TYPE 513 - PARTS LIST



R533	101-1019 1020 - up	1.8 meg 10 meg	1 w 1 w	Fixed Fixed	Comp. Prec.	10% 1%	309-020 310-107
R534	101 - up	10 k	1/2 w	Fixed	Comp.	10%	302-103
R535	101 - up	10 k	1/2 w	Fixed	Comp.	10%	302-103
R536	101 - up	470 k	1/2 w	Fixed	Comp.	10%	302-474
R537	101 - up	3.9 k	1 w	Fixed	Comp.	10%	304-392
R538	101 - up	470 $\Omega$	1/2 w	Fixed	Comp.	10%	302-471
R539	101 - up	470 k	1/2 w	Fixed	Comp.	10%	302-474
R540	101 - up	22 k	1/2 w	Fixed	Comp.	10%	302-223
R541	101 - up	20 k	2 w	Var.	WW	2%	312-003
R542	101 - up	20 $\Omega$	1/2 w	Fixed	Prec.	1%	309-064
R543	101 - up	40 $\Omega$	1/2 w	Fixed	Prec.	1%	309-066
R544	101 - up	142 $\Omega$	1/2 w	Fixed	Prec.	1%	309-071
R545	101 - up	416 $\Omega$	1/2 w	Fixed	Prec.	1%	309-079
R546	101 - up	1582 $\Omega$	1/2 w	Fixed	Prec.	1%	309-029
R547	101 - up	5.25 k	1/2 w	Fixed	Prec.	1%	309-032
R548	101 - up	13.23 k	1/2 w	Fixed	Prec.	1%	309-035
R549	101 - up	100 k	1 w	Fixed	Comp.	10%	304-104
R550	101 - up	47 k	1 w	Fixed	Comp.	10%	304-473
R551	101 - up	2.2 meg	1/2 w	Fixed	Comp.	10%	302-225
R552	101 - up	47 k	2 w	Fixed	Comp.	10%	306-473
R553	101 - up	820 k	1/2 w	Fixed	Comp.	10%	302-824
R554	101 - up	820 k	1/2 w	Fixed	Comp.	10%	302-824
R555	101 - up	680 k	1/2 w	Fixed	Comp.	10%	302-684
R556	101 - up	1.5 meg	1/2 w	Fixed	Comp.	10%	302-155
R557	101 - up	5 k	2 w	Var.	WW	20%	311-012
R558	101-396 397 - up	6.8 k 10 k	1 w 1 w	Fixed Fixed	Comp. Comp.	10% 10%	304-682 304-103
R559	101 - up	100 k	1/2 w	Fixed	Comp.	10%	302-104
R601	X947 - up	300 $\Omega$	1/2 w	Fixed	Prec.	1%	309-076



TYPE 513 - PARTS LIST

## ELECTRON TUBES

V1	101 - up	12AW6	Input pre-amplifier	Selected	157-013
V2	101 - up	12AW6	2nd stage pre-amplifier	Selected	157-013
V3	101 - up	12AT7	Preamplifier cathode-follower		154-039
V4	101 - up	12AT7	Gain Control cathode-follower	Selected	157-010
V5	101 - up	6J6	Probe power cathode-follower		154-032
V6	101 - up	12AW6	Internal trigger amplifier		154-042
V7	101 - up	12AT7	Delay line impedance matching cathode cathode-follower	Selected	157-010
V8	101 - up	12AT7	Driver cathode-follower	Selected	157-010
V9	101 - up	6AH6	Driver	Selected	157-001
V10	101 - up	6AH6	Driver	Selected	157-001
V11	101 - up	6AH6	Driver	Selected	157-001
V12	101 - up	6AH6	Driver	Selected	157-001
V14	101 - up	6AS5	Driver voltage cathode-follower		154-018
V15	101 - up	6CB6	Output Distributed Amplifier		157-004
V16	101 - up	6CB6	Output Distributed Amplifier		157-004
V17	101 - up	6CB6	Output Distributed Amplifier		157-004
V18	101 - up	6CB6	Output Distributed Amplifier		157-004
V19	101 - up	6CB6	Output Distributed Amplifier		157-004
V20	101 - up	6CB6	Output Distributed Amplifier		157-004
V21	101 - up	6CB6	Output Distributed Amplifier		157-004
V22	101 - up	6CB6	Output Distributed Amplifier		157-004
V23	101 - up	6CB6	Output Distributed Amplifier		157-004
V24	101 - up	6CB6	Output Distributed Amplifier		157-004
V25	101 - up	6CB6	Output Distributed Amplifier		157-004
V26	101 - up	6CB6	Output Distributed Amplifier		157-004
V27	101 - up	6CB6	Output Distributed Amplifier		157-004
V28	101 - up	6CB6	Output Distributed Amplifier		157-004

TYPE 513 - PARTS LIST



V101	101 - up	6AH6	Trigger Inverter	154-013
V102A	101 - up	1/2 6AL5	Trigger amplifier dc restorer	154-016
V102B	101 - up	1/2 6AL5	Coupling Diode	
V103	101 - up	6AG7	Trigger amplifier	154-012
V104	101-164 165 - up	6CB6 6AH6	Sweep multivibrator Sweep multivibrator	154-030 154-013
V105	101 - up	6AG7	Sweep multivibrator	154-012
V106	101 - up	6AG7	Sweep generator clamp tube	154-012
V107	101 - up	6C4	Sweep charging potential cathode-follower	154-029
V108	101 - up	6AL5	Sweep dc restorer	154-016
V109	101 - up	12AU7	Sweep amplifier, phase inverter	154-041
V110	101 - up	6AQ5	Sweep amplifier	154-017
V111	101 - up	6AQ5	Sweep amplifier	154-017
V112	101 - up	6CB6	Sweep dc level control	154-030
V113	101 - up	6CB6	Sweep dc level control	154-030
V114A	101 - up	1/2 12AU7	+ Gate output cathode-follower	154-041
V114B	101 - up	1/2 12AU7	Astigmatism potential cathode-follower	
V115	101-1412 1413 - up	12AT7 6BK7	Unblanking amplifier, inverter Unblanking amplifier, inverter	154-039 154-027
V116	101 - up	6C4	Unblanking cathode-follower	154-029
V117	101-1412 1413 - up	12AT7 6BK7	Sweep length multivibrator Sweep length multivibrator	154-039 154-027
V118	101-164	12AU7	Sweep output	154-041
V118.1	X165 - up	6C4	Sweep output cathode-follower	154-029
V118.2	X165 - up	6AL5	Sweep Magnifier	154-032
V119	101 - up	6J6	Sweep magnifier	154-032
V120	101-1887 1888 - up	5XP2 T51P2	Cathode-Ray Tube Cathode-Ray Tube	154-066 154-081
V401	101 - up	6X4	+ 800 v rectifier, doubler	154-035
V402	101 - up	6X4	+ 800 v rectifier, doubler	154-035
V403	101-1034 1035 - up	6AS5 12B4	+ 800 v series regulator + 800 v series regulator	154-018 154-044



TYPE 513 - PARTS LIST

V404	101 - up	6AU6	+ 800 v regulator amplifier	154-022
V405	101 - up	6AU5	+ 275 v series regulator	154-021
V406	101 - up	6AU6	+ 275 v regulator amplifier	154-021
V407	101 - up	6AS7	+ 275 v series regulator	154-020
V408	101 - up	6AU6	+ 225 v regulator amplifier	154-022
V409	101 - up	12AX7	+ 225 v regulator comparator	154-043
V410	101 - up	5651	+ 225 v voltage reference	154-052
V411.1	101 - up	6X4	-150 v rectifier	154-035
V411.2	101 - up	6X4	-150 v rectifier	154-035
V412	101 - up	OD3	-150 v shunt regulator	154-003
V413	101 - up	6AU6	High-voltage oscillator regulator	154-021
V414	101 - up	6AU6	High-voltage oscillator	154-021
V415	101 - up	12AU7	High-voltage regulator comparator	154-041
V416.1	101 - up	5642	+10KV rectifier, tripler	154-051
V417.1	101 - up	5642	+10KV rectifier, tripler	154-051
V418.1	101 - up	5642	-2000 V rectifier	154-051
V419	101 - up	5642	+ 2000 V rectifier tripler	154-051
V420	X1613 - up	OD3	-150 v voltage reference	154-003
V501	101 - up	12AU7	Delayed Gate Multivibrator	154-041
V502A	101 - up	1/2 12AT7	Delayed gate cathode-follower	154-039
V502B	101 - up	1/2 12AT7	Blocking oscillator trigger tube	
V503	101 - up	12AT7	Delayed trigger blocking oscillator	154-039
V504	101-2010	12AT7	Delayed trigger output cathode-follower	154-039
	2011 - up	12BH7	Delayed trigger output cathode-follower	154-046
V507	101 - up	6J6	Trigger rate gen. blocking oscillator	154-032
V508	101 - up	12AT7	Trigger rate gen. cathode-follower	154-039
V509	101 - up	12AU7	Cal. multivibrator	154-041
V510	101 - up	12AU7	Cal. limiter and cathode-follower	154-041

TYPE 513 - PARTS LIST





### FUSES

F401	101-1412	6 1/4 Amp.	Slo-Blo	4AG	159-012
	1413 - up	6 1/4 Amp.	Slo-Blo	3AG	159-011

### TRANSFORMERS

T401	Plate and Heater Supply		T513PB3		120-023
	Primary	117 or 234 v 50/60 cycle			
	Secondaries	82 v, 150 ma			
		6.5 v, 8A			
		6.5 v, 0.6A			
		6.5 v, 0.6A, insulated for 1000 VDC			
		6.5 v, 6.5 A			
		6.5 v, 0.8A, insulated for 1000 VDC			
		6.5 v, 1.2A, insulated for 2500 VDC			
		6.5 v, 0.6A, insulated for 1500 VDC			
		6.5 v, 0.6A, connected to 280v winding			
		6.5 v, 0.6A, connected to 280v winding			
		6.5 v, 0.5A			
		6.5 v, 8A			
T402	101 - up	Part of 210B power supply. 210B			120-032
T501	101 - up	Blocking osc. transformer, 3 windings, ratio 1/1/1. T11A3			120-035
T502	101-1019	T11A1			120-001
	1020 - up	Blocking Osc., transformer, 3 windings, ratio 1/1/1. T21A3			120-049

### SWITCHES

						wired	unwired
SW101	101 - up	2 wafer	6 position	rotary	TRIGGER SELECTOR		260-005
SW102	101 - up	2 wafer	6 position	rotary	SWEEP TIME (rear)	262-054	260-049
SW103	101 - up	2 wafer	10 position	rotary	SWEEP TIME MULTIPLIER	262-034	260-035
SW104	101 - up	Single Pole, Double Throw, toggle			SWEEP MAGNIFIER	Furnished with R206	
SW401	101 - up	Single Pole, Double Throw, toggle			POWER	260-067	
		6 Amp., 250 v:					
SW501	101 - up	Double-Pole, Single-Throw, toggle			DELAY TRIGGER	Furnished with R501	
SW502	101 - up	2 wafer	6 position	rotary	TRIGGER RATE GENERATOR	262-035	260-034



## NOTE

Unless otherwise specified, all of the voltage readings were taken with a dc vacuum-tube voltmeter having an input resistance of 11 megohms. The waveforms shown were reproduced from actual photographs. There will be considerable variation between instruments because of normal manufacturing tolerances and vacuum-tube characteristics. Therefore, the significance of any discrepancies observed should be determined by referring to the circuit diagram.

All readings are in volts unless otherwise specified. Where two voltage readings are given, they represent the voltage as read by a voltmeter under two sets of conditions, and, as such, do not indicate the peak-to-peak excursion of voltage at the point.

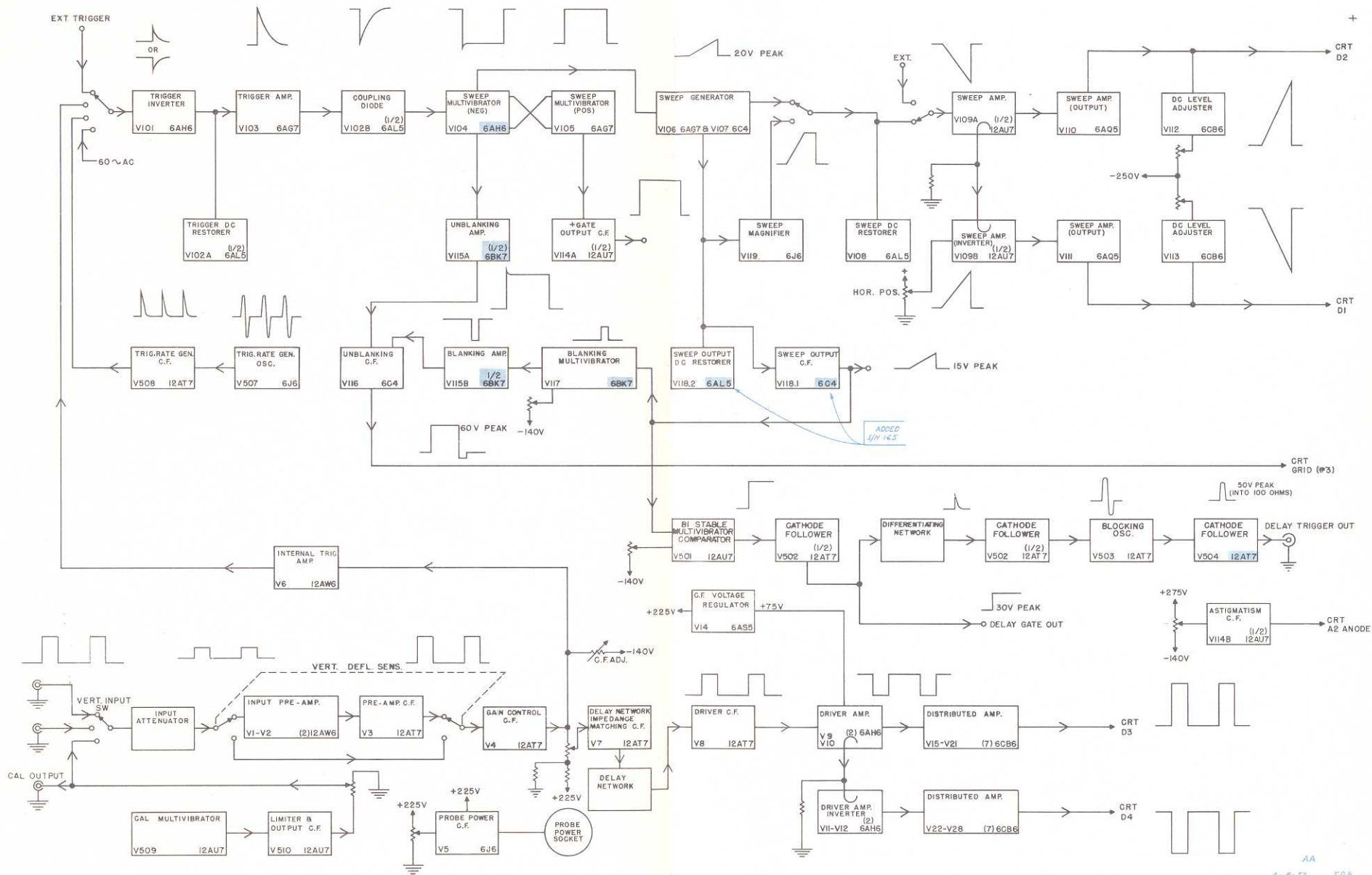

TYPE 513 OSCILLOSCOPE

AA

SEE PARTS LIST FOR EARLIER TYPES OF TUBES MARKED

BLOCK DIAGRAM

3-3-54  
L.A.P. 368

AA  
4-8-57 T.R.B.



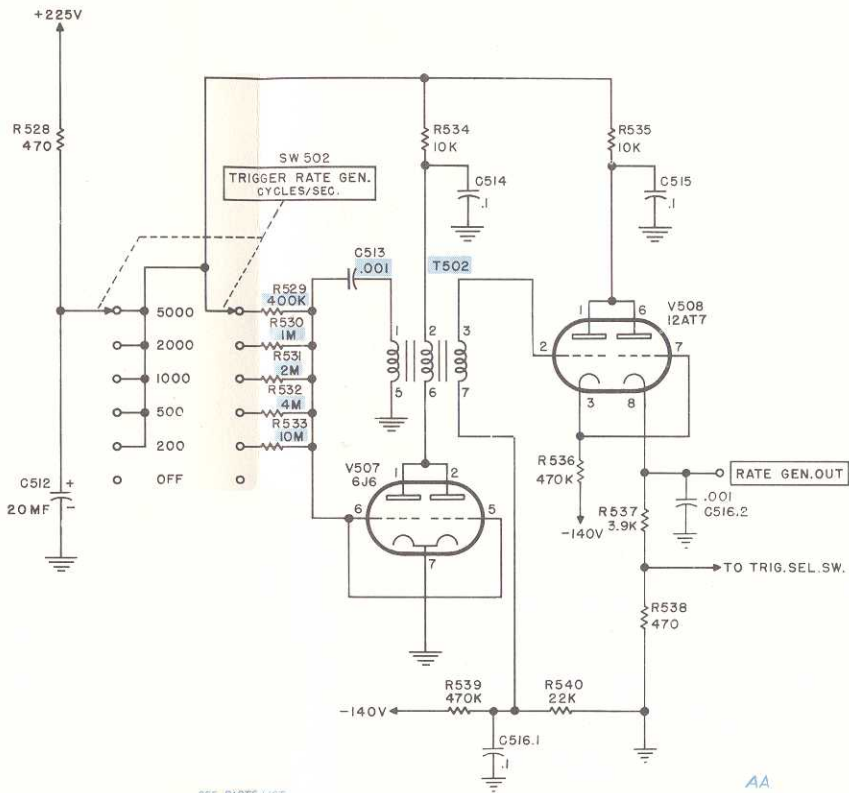

NOTE:

CAPACITOR VALUES 1 AND LARGER ARE IN PICOFARADS ( $10^{-12}$  FARADS), VALUES LESS THAN 1 ARE IN MICROFARADS ( $10^{-6}$  FARADS) UNLESS OTHERWISE STATED

SEE PARTS LIST FOR EARLIER VALUES OF PARTS MARKED

AA

4-8-59 T.D.B.

L.A.P.  
2-6-53

TYPE 513 CATHODE-RAY OSCILLOSCOPE

AA

TRIGGER RATE GENERATOR

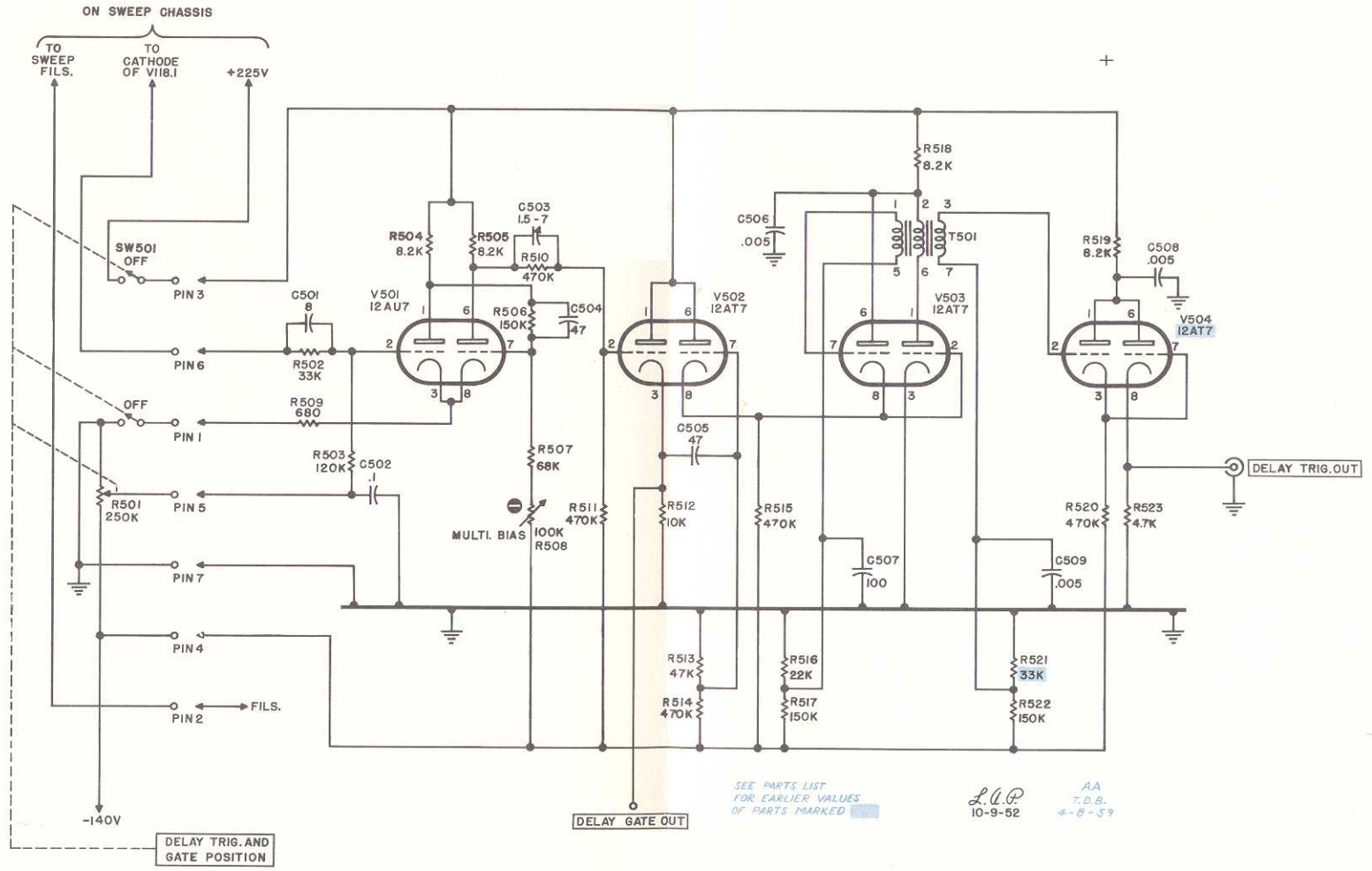

+

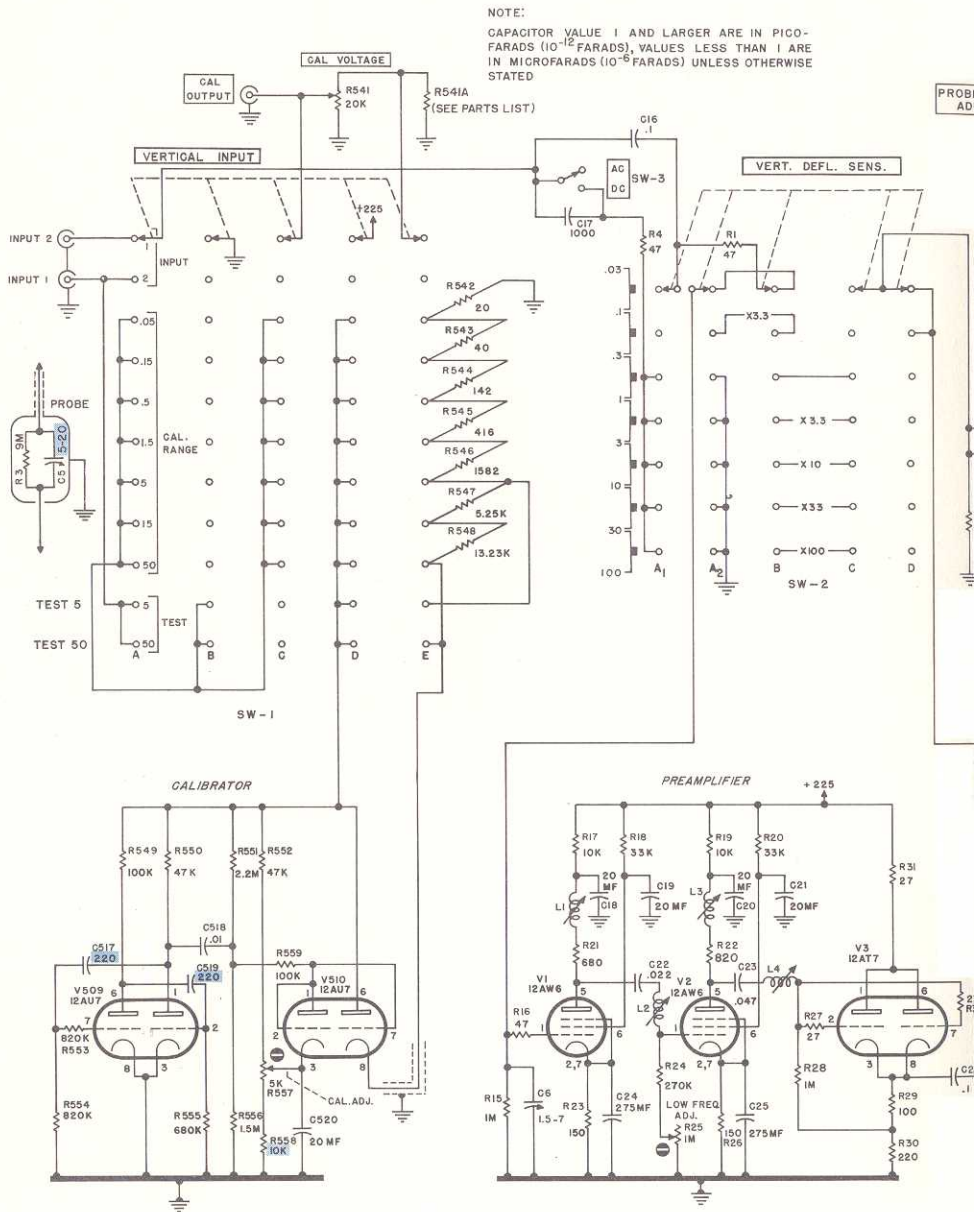

TYPE 513 OSCILLOSCOPE

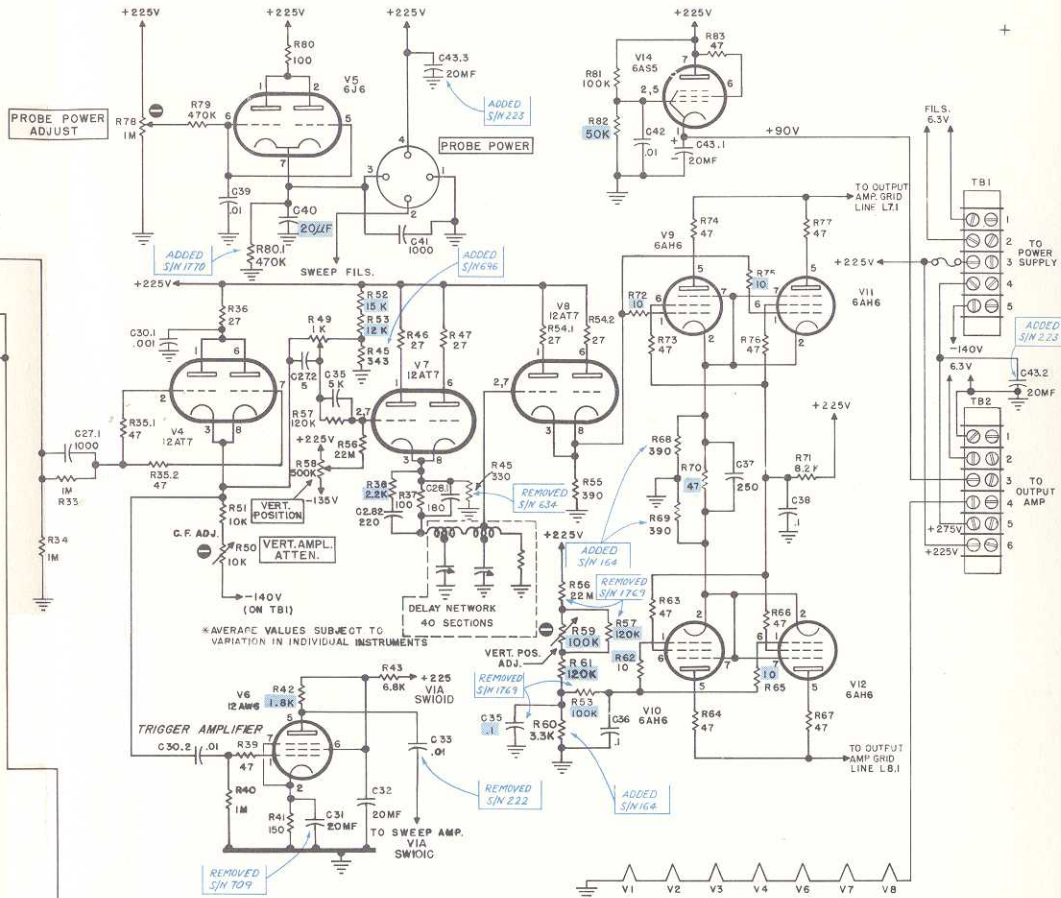

VERTICAL DEFLECTION SENSITIVITY, SW-2

SW-2 A <sub>1</sub> , B		SW-2 C, D				
POSITION 1	POSITION 2	POSITION 3	POSITION 4	POSITION 5	POSITION 6	POSITION 7
.03 - .1 V/cm	.1 - .3 V/cm	.3 - 1 V/cm	1 - 3 V/cm	3 - 10 V/cm	10 - 30 V/cm	30 - 100 V/cm
RATIO 1-1	RATIO 3.3-1	RATIO 1-1	RATIO 3.3-1	RATIO 10-1	RATIO 33-1	RATIO 100-1

6-22-54 L.A.P. 4-8-57 T.D.B. AA

VERTICAL AMPLIFIER AND CALIBRATOR

SEE PARTS LIST FOR EARLIER VALUES OF PARTS MARKED

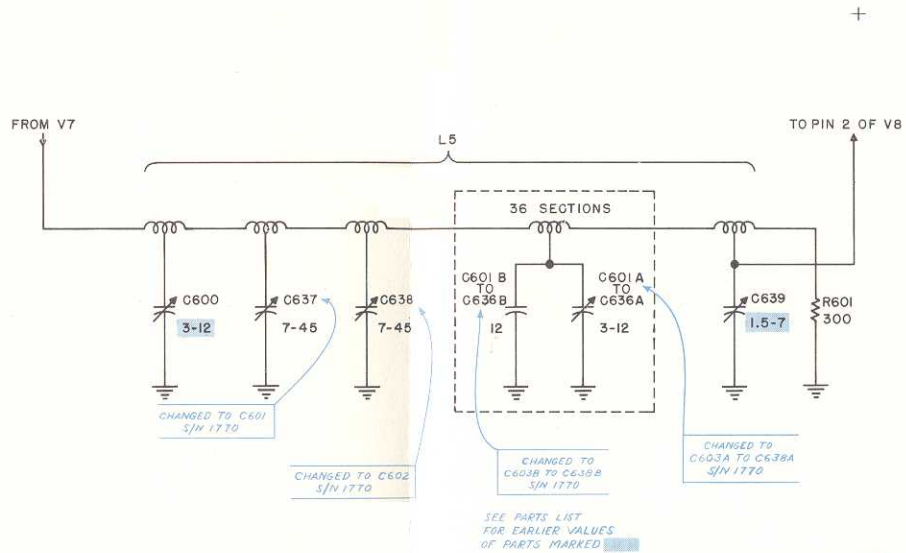

AA  
4-8-59 T.D.B.

10-7-52 L.A.P.

TYPE 513 CATHODE-RAY OSCILLOSCOPE

AA

DELAY NETWORK





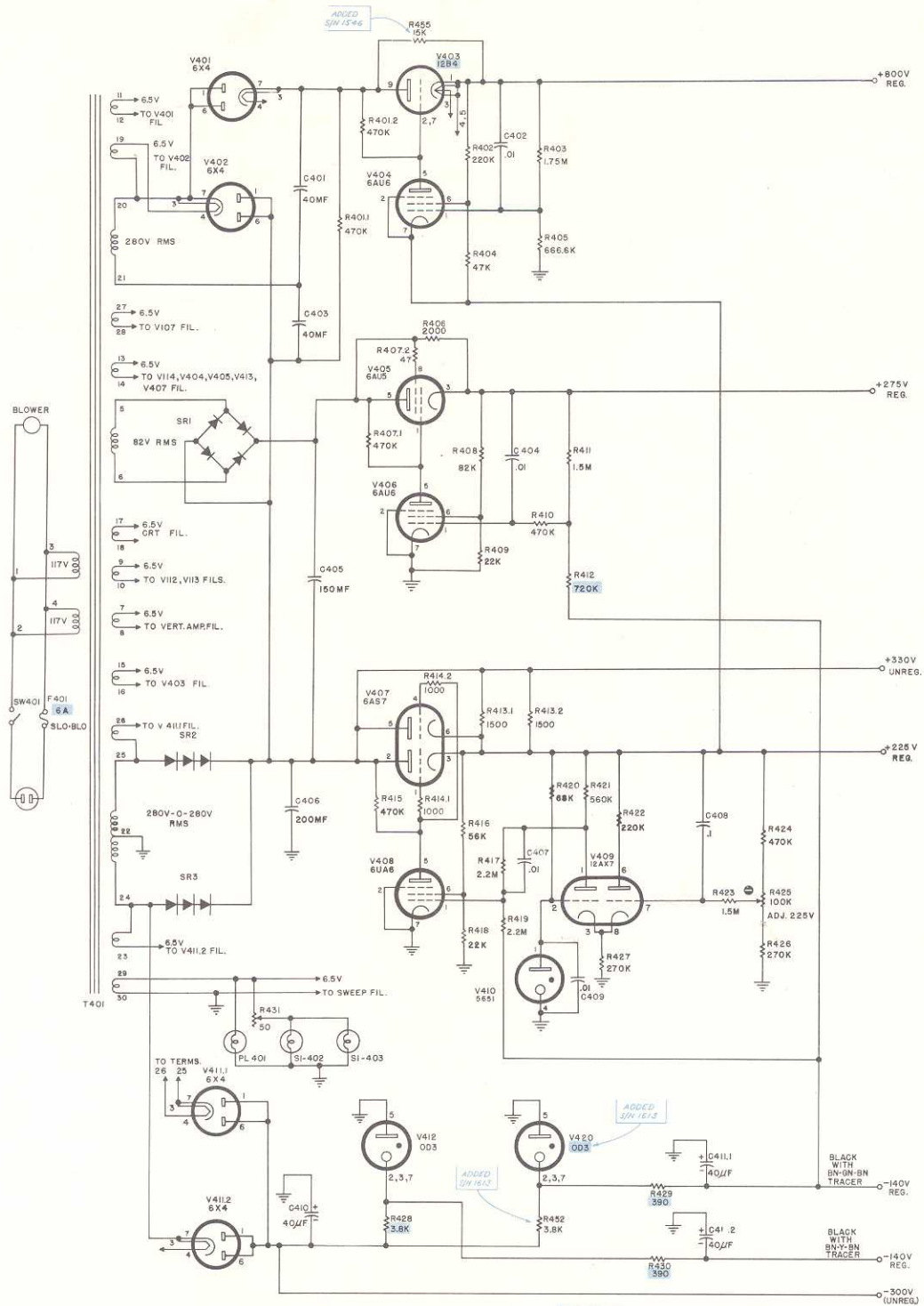

TYPE 513 OSCILLOSCOPE

AA

POWER SUPPLY

3-1-54  
4112 C57

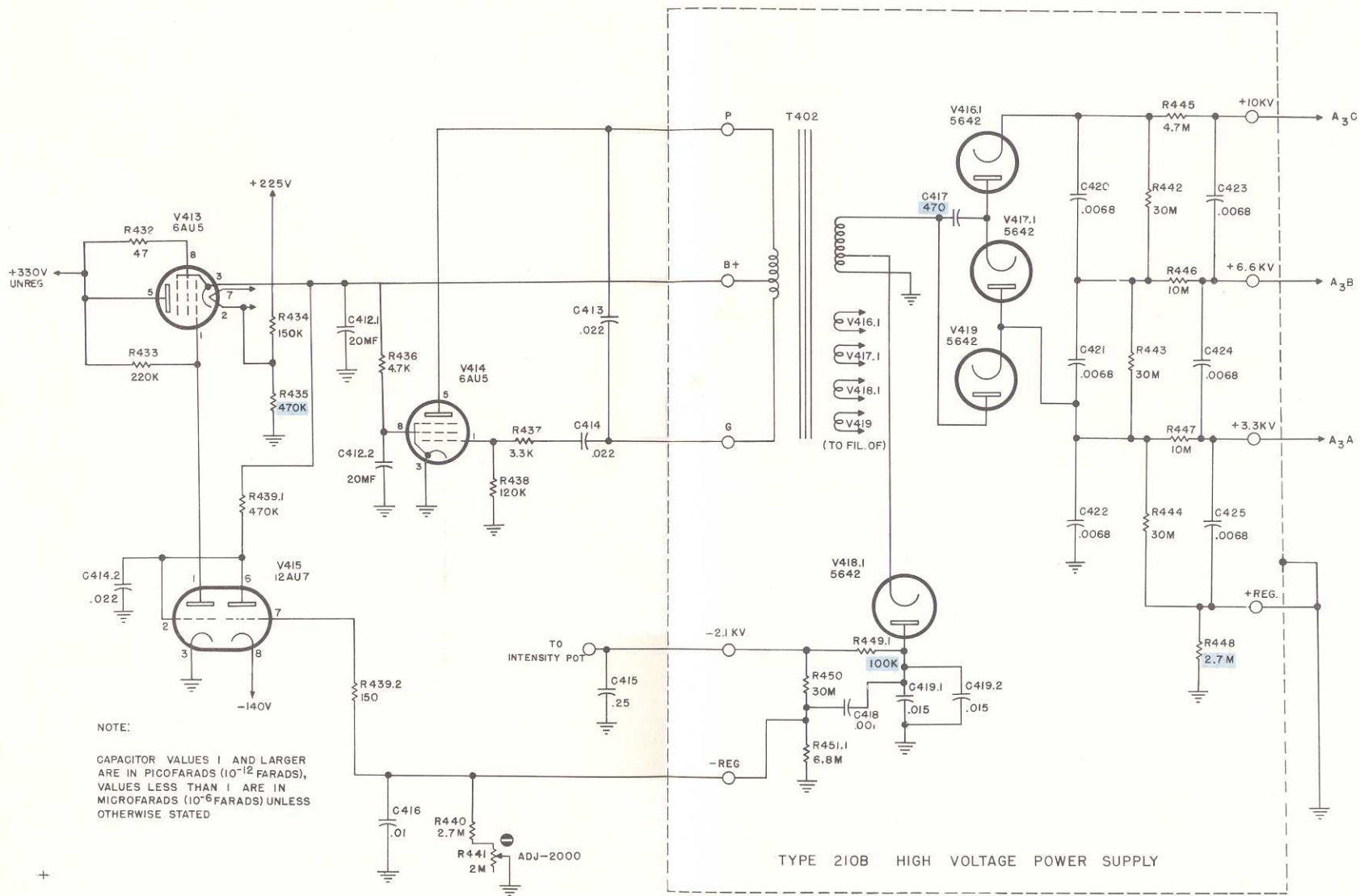

SEE PARTS LIST FOR EARLIER VALUES OF PARTS MARKED

AA  
T.O.S.  
4-8-59

LAP EES  
10-30-52

### **ABBREVIATIONS USED IN OUR PARTS LISTS**

Cer.	ceramic	m	milli
Comp.	composition	$\Omega$	ohm
EMC	electrolytic, metal cased	Poly.	polystyrene
EMT	electrolytic, metal tubular	Prec.	precision
f	farad	PT	paper tubular
h	henry	Tub.	tubular
k	thousands of ohms	v	working volts dc
meg	megohms	Var.	variable
$\mu$	micro	w	watt
$\mu\mu$	micromicro	WW	wire wound
	GMV		guaranteed minimum value

### **ABBREVIATIONS USED IN OUR CIRCUIT DIAGRAMS**

Resistance values are in ohms. The symbol k stands for thousands. A resistor marked 2.7 k has a resistance of 2,700 ohms. The symbol M stands for million. For example, a resistor marked 5.6 M has a resistance of 5.6 megohms.

Unless otherwise specified on the circuit diagram, capacitance values marked with the number 1 and numbers greater than 1 are in  $\mu\mu\text{f}$ . For example, a capacitor marked 3.3 would have a capacitance of 3.3 micromicrofarads. Capacitance values marked with a number less than 1 are in  $\mu\text{f}$ . For example, a capacitor marked .47 would have a capacitance of .47 microfarads.

Inductance values marked in mh are in millihenrys. Inductance values marked in  $\mu\text{h}$  are in microhenrys.

Your instrument **WARRANTY** appears on the reverse side of this sheet.

SERIAL NO. \_\_\_\_\_

## **IMPORTANT**

Include the INSTRUMENT TYPE and the above SERIAL NUMBER in any correspondence regarding this instrument. The above serial number must match the instrument serial number if parts are to be ordered from the manual. Your help in this will enable us to answer your questions or fill your order with the least delay possible.



## **WARRANTY**

All Tektronix instruments are fully guaranteed against defective materials and workmanship for one year. Should replacement parts be required, whether at no charge under warranty or at established net prices, notify us promptly, including sufficient details to identify the required parts. We will ship them pre-paid (via air if requested) as soon as possible, usually within 24 hours.

Tektronix transformers, manufactured in our own plant, carry an indefinite warranty.

All price revision and design modification privileges reserved.